

# Combined Stress

- Axial vs. Eccentric Load
- Combined Stress
- Interaction Formulas

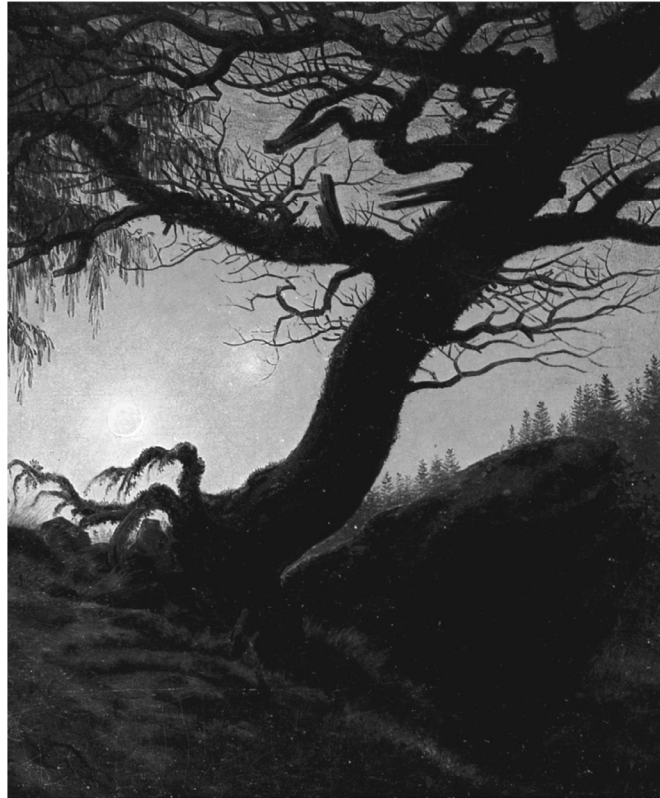

from "Man und Frau den Mond betrachtend"  
1830-35 by Caspar David Friedrich  
Alte Nationalgalerie, Berlin

## NDS - 3.9 Combined Bending and Axial Loading types and applications

**Figure 3G Combined Bending and Axial Tension**

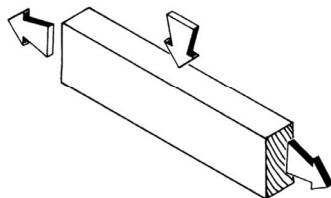

### 3.9.2 Bending and Axial Compression

**Figure 3H Combined Bending and Axial Compression**

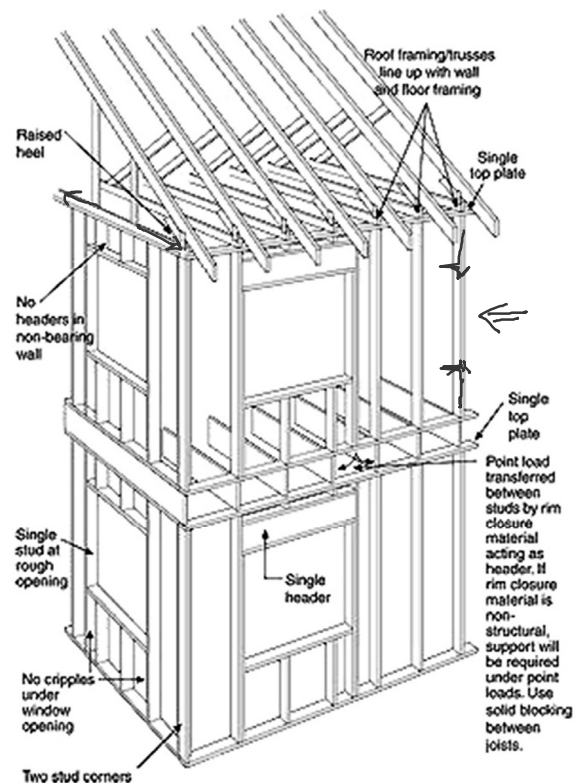
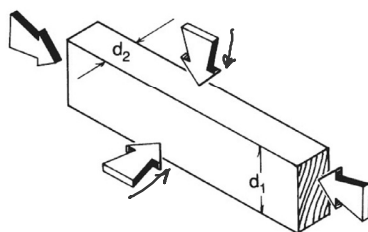

# NDS 3.9.1 Bending and Axial Tension

two conditions

## 3.9.1 Bending and Axial Tension

Members subjected to a combination of bending and axial tension (see Figure 3G) shall be so proportioned that:

$$\frac{f_t}{F_t'} + \frac{f_b}{F_b'} \leq 1.0 \quad \text{TENSION CRIT.} \quad (3.9-1)$$

and

$$\frac{f_b - f_t}{F_b''} \leq 1.0 \quad \text{FLEXURE CRIT.} \quad (3.9-2)$$

where:

$F_b'$  = reference bending design value multiplied by all applicable adjustment factors except  $C_L$

$F_b''$  = reference bending design value multiplied by all applicable adjustment factors except  $C_C$

**Figure 3G Combined Bending and Axial Tension**

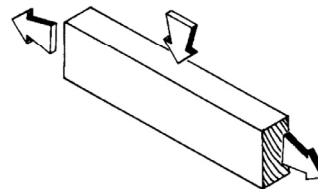

# NDS 3.9.1 Bending and Axial Tension

NDS Equations

CASE 1. Tension is critical. eq. 3.9-1  
\* no  $C_L$

CASE 2. Flexure is critical. eq. 3.9-2  
\*\* no  $C_V$

$$\frac{f_t}{F_t'} + \frac{f_b}{F_b'} \leq 1.0$$

$$\frac{f_b - f_t}{F_b''} \leq 1.0$$

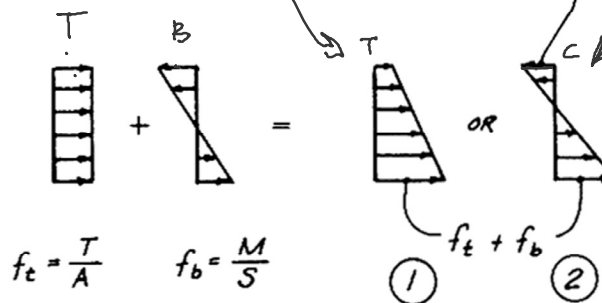
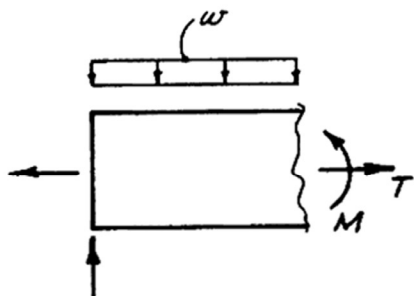

TENSION + BENDING = COMBINED STRESSES

# NDS 3.9.1 Bending and Axial Tension

tension + bending

**Figure 3G Combined Bending and Axial Tension**

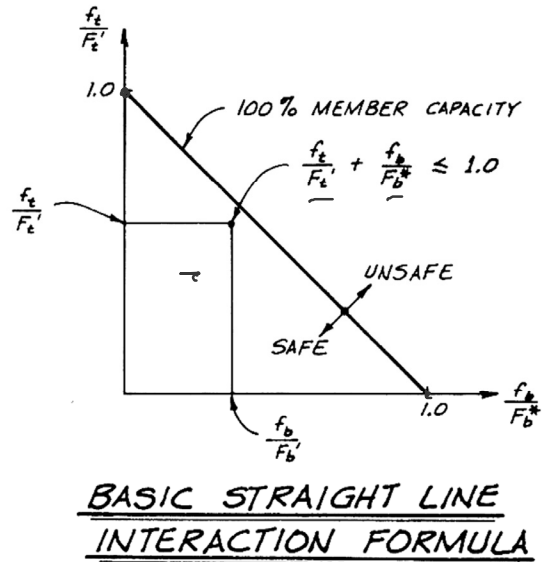
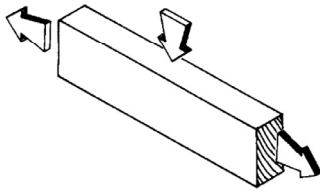

# NDS 3.9.2 Bending and Axial Compression

two axis bending + compression

## 3.9.2 Bending and Axial Compression

Members subjected to a combination of bending about one or both principal axes and axial compression (see Figure 3H) shall be so proportioned that:

$$\left[ \frac{f_c}{F_c'} \right]^2 + \frac{f_{b1}}{F_{b1} \left[ 1 - \left( \frac{f_c}{F_{cE1}} \right)^2 \right]} + \frac{f_{b2}}{F_{b2} \left[ 1 - \left( \frac{f_c}{F_{cE2}} \right) - \left( \frac{f_{b1}}{F_{bE}} \right)^2 \right]} \leq 1.0 \quad (3.9-3)$$

*Handwritten notes: "EDGEWISE" above f<sub>b1</sub>, "FLAT" above f<sub>b2</sub>, "AMPLIFICATION" next to the denominator of the second term.*

and (Flatwise bending + compression)

$$\frac{f_c}{F_{cE2}} + \left( \frac{f_{b1}}{F_{bE}} \right)^2 < 1.0 \quad (3.9-4)$$

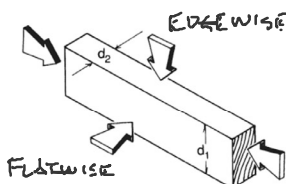

$$f_c = \frac{P}{A}$$

$$f_b = \frac{M}{S}$$

where:

$$f_c < F_{cE1} = \frac{0.822 E_{min}'}{(l_{e1} / d_1)^2} \quad \text{for either uniaxial edgewise bending or biaxial bending}$$

and

$$f_c < F_{cE2} = \frac{0.822 E_{min}'}{(l_{e2} / d_2)^2} \quad \text{for uniaxial flatwise bending or biaxial bending}$$

and

$$f_{b1} < F_{bE} = \frac{1.20 E_{min}'}{(R_B)^2} \quad \text{for biaxial bending}$$

f<sub>b1</sub> = actual edgewise bending stress (bending load applied to narrow face of member), psi

f<sub>b2</sub> = actual flatwise bending stress (bending load applied to wide face of member), psi

d<sub>1</sub> = wide face dimension (see Figure 3H), in.

d<sub>2</sub> = narrow face dimension (see Figure 3H), in.

# NDS 3.9.2 Bending and Axial Compression

three possible combinations

$$\left[ \frac{f_c}{F'_c} \right]^2 + \frac{f_{b1}}{F_{b1}' [1 - (f_c/F_{cE1})]} \leq 1.0$$

COMP. + FLEXURE X-X

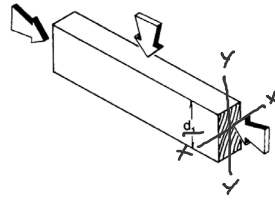

$$f_c < F_{cE1} = \frac{0.822 E_{min}'}{(l_{e1}/d_1)^2}$$

$$\left[ \frac{f_c}{F'_c} \right]^2 + \frac{f_{b2}}{F_{b2}' [1 - (f_c/F_{cE2}) - (f_{b1}/F_{bE})^2]} \leq 1.0$$

COMP. + FLEXURE Y-Y

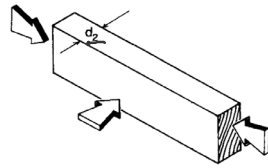

$$f_c < F_{cE2} = \frac{0.822 E_{min}'}{(l_{e2}/d_2)^2}$$

$$\left[ \frac{f_c}{F'_c} \right]^2 + \frac{f_{b1}}{F_{b1}' [1 - (f_c/F_{cE1})]} + \frac{f_{b2}}{F_{b2}' [1 - (f_c/F_{cE2}) - (f_{b1}/F_{bE})^2]} \leq 1.0$$

COMP. + FLEXURE X-X + FLEXURE Y-Y

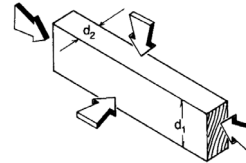

$$f_{b1} < F_{bE} = \frac{1.20 E_{min}'}{(R_B)^2}$$

# NDS 3.9.2 Bending and Axial Compression

strong axis bending + compression

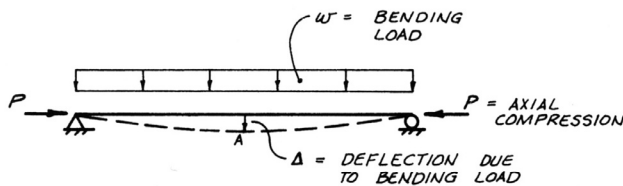

$$\left[ \frac{f_c}{F'_c} \right]^2 + \frac{f_{b1}}{F_{b1}' \frac{1}{[1 - (f_c/F_{cE1})]}} \leq 1.0$$

AMPLIFICATION FACTOR

COMP. + FLEXURE X-X

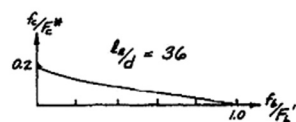
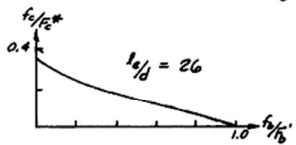
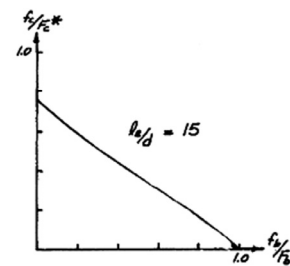
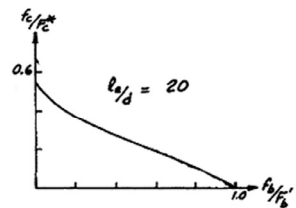
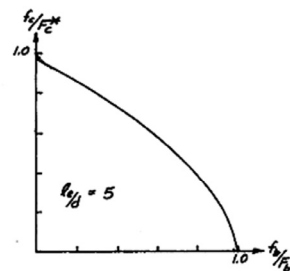

Interaction graphs for different slenderness ratios - Breyer

# Second Order Stress

"P Delta Effect"

With larger deflections this can become significant.

1. Eccentric load causes bending moment
2. Bending moment causes deflection,  $\Delta$
3.  $P \times \Delta$  causes additional moment

Accounted for by use of an amplification factor

$$\left[ \frac{f_c}{F'_c} \right]^2 + \frac{f_{b1}}{F_{b1}'} \frac{1}{\left[ 1 - (f_c / F_{ce1}) \right]} \leq 1.0$$

AMPLIFICATION FACTOR

**COMP. + FLEXURE X-X**

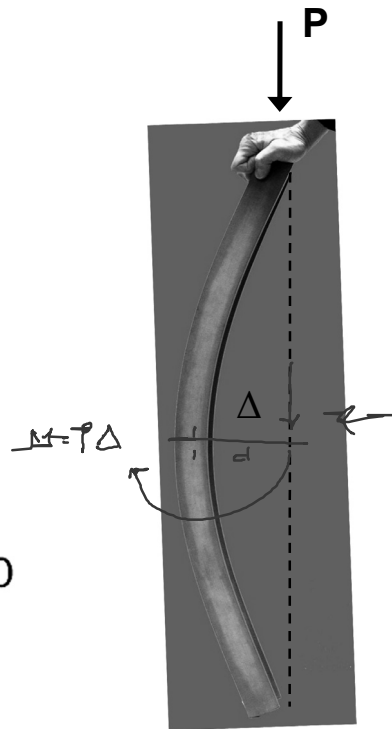

## Examples

combined stress

Columns with side loading

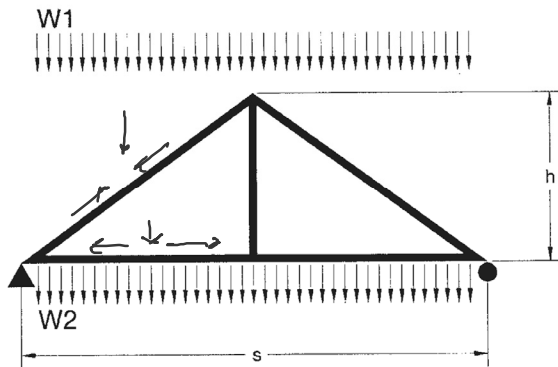
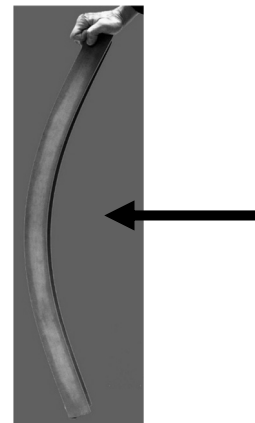

Trusses loaded on members

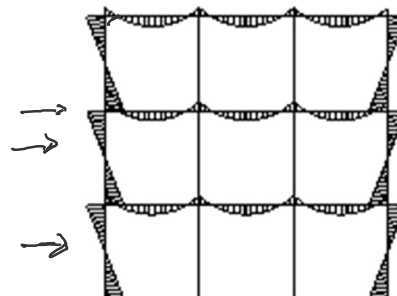

Continuous beams

# Other Examples

combined stress

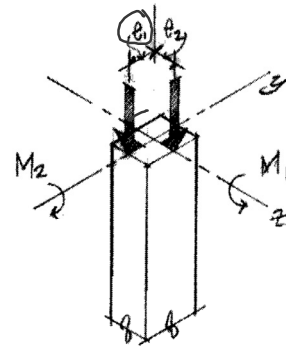
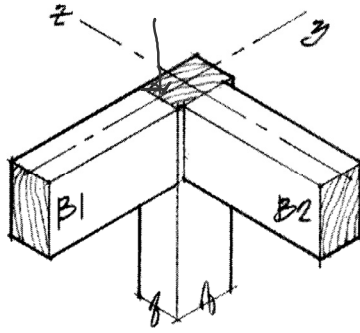

$$M_1 = P_1 \times e_1 \text{ (ABOUT THE } x\text{-axis)}$$

$$M_2 = P_2 \times e_2 \text{ (ABOUT THE } z\text{-axis)}$$

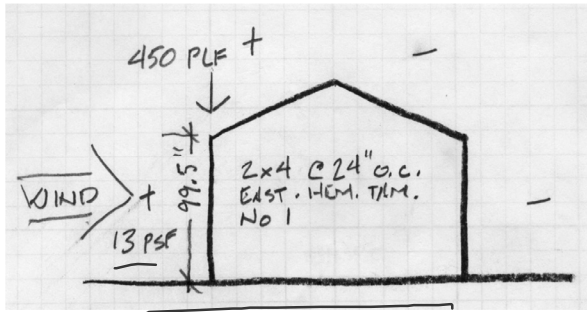

## Example Problem

Given: Queen Post truss

Hem-Fir No.1 & Better

$$F_b = 1100 \text{ psi}$$

$$F_t = 725 \text{ psi}$$

$$F_c = 1350 \text{ psi}$$

$$E_{min} = 550000 \text{ psi}$$

span = 30 ft. spaced 4 ft. o.c.

Projected Roof Load:

$$D = 14 \text{ psf} + S = 30 \text{ psf} = 44 \text{ psf}$$

Attic + Ceiling:

$$D = 8 \text{ psf}$$

bottom chord: 2x8 (1.5" x 7.25")

top chord: 2x10 (1.5" x 9.25")

Find: pass/fail

1. Determine truss joint loading

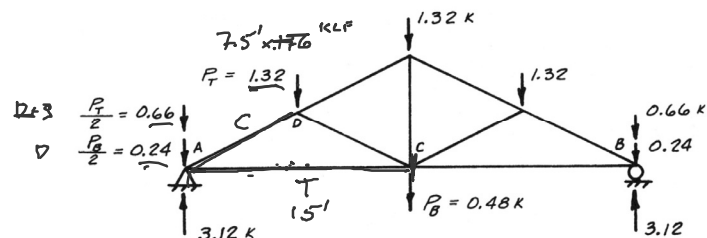
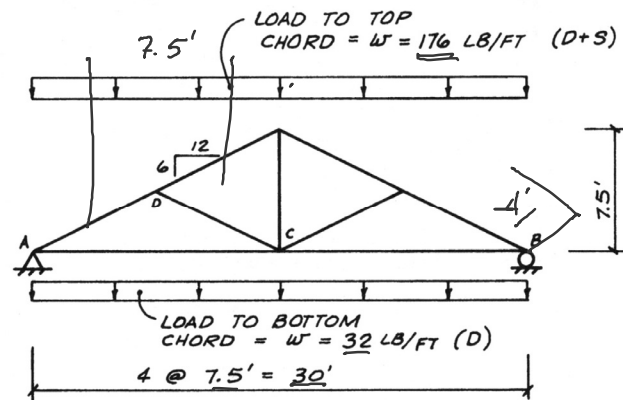

# Example

truss reactions and member forces

- Determine the external **end reactions** of the whole truss. The geometry and loads are symmetric, so each reaction is  $\frac{1}{2}$  of the total load.
- Use an FBD of the reaction joint to find the **chord forces**. Sum the forces horizontal and vertical to find the components.

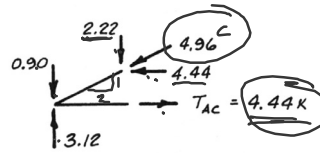
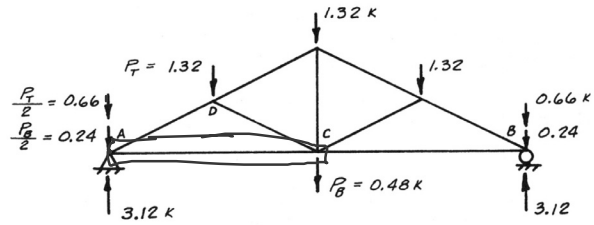

D+S Load:

Top chord = 4.96 k compression  
 Bottom chord = 4.44 k tension

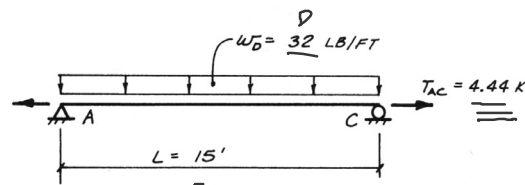

# Example

bottom chord 2x8 – bending + tension

- Determine controlling load case:

Tension Force: D+S  

$$\frac{P_t}{C_D} = 4.44 \text{ lbs} / 1.15 = 3.86 \text{ (controls)}$$

Tension Force: D  

$$\frac{P_t}{C_D} = 1.74 \text{ k} / 0.9 = 1.93$$

## D+S

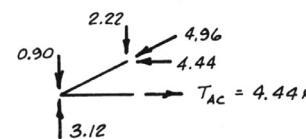
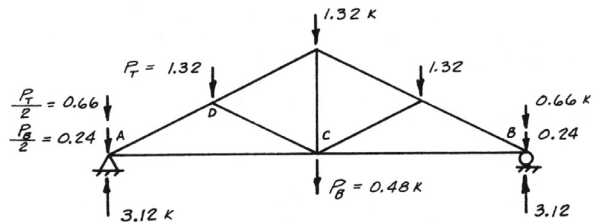

## D alone

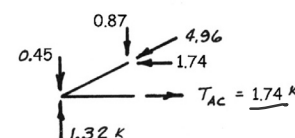
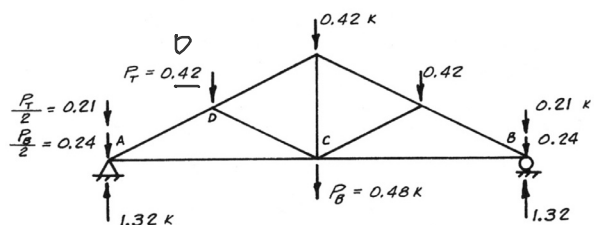

## Example

bottom chord 2x8 – bending + tension

$$\frac{f_t}{F_t'} + \frac{f_b}{F_b'} \leq 1.0$$

$$\frac{f_b - f_t}{F_b'} \leq 1.0$$

D+S

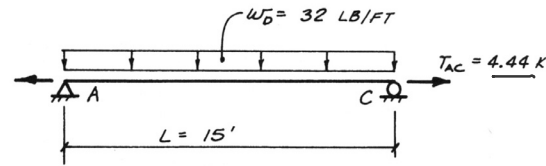

5. Calculate the **actual** axial and flexural stress.

$$f_t = 408.3 \text{ psi}$$

$$f_b = 821.9 \text{ psi}$$

$$f_t = \frac{P_T}{A_n} = \frac{4440 \text{ lbs}}{\frac{10.875 \text{ in}^2}{2 \times 8}} = 408.3 \text{ psi}$$

$$f_b = \frac{M}{S_x} = \frac{900 (12)}{13.14 \text{ in}^3} = 821.9 \text{ psi}$$

$$M = \frac{w l^2}{8} = \frac{32 (15)^2}{8} = 900 \text{ ft} \cdot \text{lb}$$

$$S_x = \frac{13.14 \text{ in}^3}{2 \times 8}$$

## Example

bottom chord 2x8 – bending + tension

Hem-Fir No.1 & Better

$$F_b = 1100 \text{ psi}$$

$$F_t = 725 \text{ psi}$$

~~C<sub>L</sub>~~ is 1.0 BY 4.4.1  
d/b = 4, ENDS ARE HELD

6. Determine **allowable** stresses using applicable factors:

Tension: D+S

$$F_t' = F_t (C_D C_F)$$

$$F_t' = 725 (1.15 \cdot 1.2) = 1000 \text{ psi}$$

$$F_t' = 1000 > 408.3 = f_t \text{ ok } \checkmark$$

Flexure: D+S

$$F_b' = F_b (C_D C_L C_F)$$

$$F_b' = 1100 (1.15 \cdot 1.0 \cdot 1.2) = 1518 \text{ psi}$$

$$F_b' = 1518 > 821.9 = f_b \text{ ok } \checkmark$$

Size Factors,  $C_F$

		$F_b$		$F_t$	$F_c$
		Thickness (breadth)			
Grades	Width (depth)	2" & 3"	4"		
Select Structural, No.1 & Btr, No.1, No.2, No.3	2", 3", & 4"	1.5	1.5	1.5	1.15
	5"	1.4	1.4	1.4	1.1
	6"	1.3	1.3	1.3	1.1
	8"	1.2	1.3	1.2	1.05
	10"	1.1	1.2	1.1	1.0
Stud	12"	1.0	1.1	1.0	1.0
	14" & wider	0.9	1.0	0.9	0.9
	2", 3", & 4"	1.1	1.1	1.1	1.05
Construction Standard	5" & 6"	1.0	1.0	1.0	1.0
	8" & wider	Use No.3			
Utility	2", 3", & 4"	1.0	1.0	1.0	1.0
	4"	1.0	1.0	1.0	1.0
	2" & 3"	0.4	—	0.4	0.6



# Example

bottom chord 2x8 – combined stress

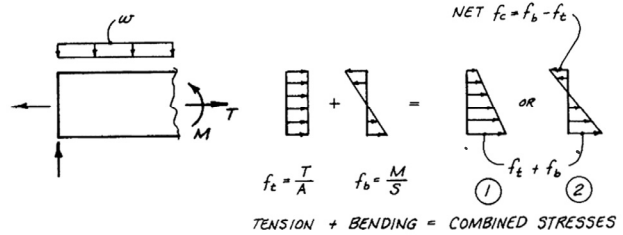

## 3.9.1 Bending and Axial Tension

Members subjected to a combination of bending and axial tension (see Figure 3G) shall be so proportioned that:

$$\frac{f_t}{F_t'} + \frac{f_b}{F_b''} \leq 1.0 \quad \text{TENSION CRIT.} \quad (3.9-1)$$

and

$$\frac{f_b - f_t}{F_b''} \leq 1.0 \quad \text{FLEXURE CRIT.} \quad (3.9-2)$$

where:

$F_b'$  = reference bending design value multiplied by all applicable adjustment factors except  $C_L$

$F_b''$  = reference bending design value multiplied by all applicable adjustment factors except  $C_V$

(3.9-1)

$$\frac{f}{F} = \frac{408.3}{1000} + \frac{821.9}{1518}$$

$$0.4083 + 0.5414 = 0.95 \checkmark$$

$$0.95 < 1.0 \quad \text{PASS}$$

(3.9-2)

$$\frac{f_b - f_t}{F_b''} = \frac{821.9 - 408.3}{1518} = 0.2724$$

$$0.27 < 1.0 \quad \text{PASS}$$

# Example

top chord 2x10 – bending + compression

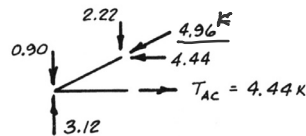

D+S

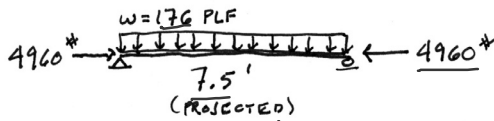
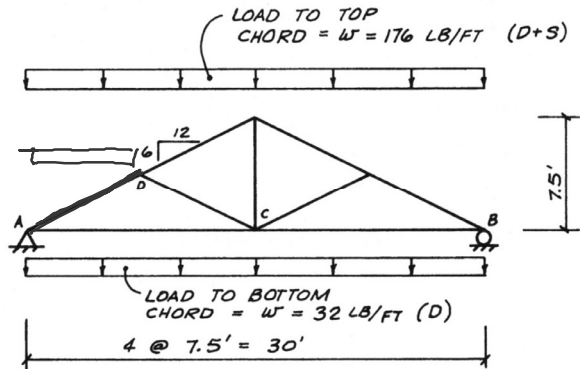

$$M = \frac{w l^2}{8} = \frac{176 \text{ PLF} (7.5')^2}{8} = 1237.5 \text{'}-*$$

$$S_x = 21.39 \text{ in}^3$$

2x10

4. Calculate the **actual** axial and flexural stress.

$$f_c = 357.5 \text{ psi}$$

$$f_c = \frac{P}{A} = \frac{4960^*}{1.5 \times 9.25} = 357.5 \text{ psi}$$

$$f_b = 694.2 \text{ psi}$$

$$f_b = \frac{M}{S_x} = \frac{1237.5 (12)}{21.39} = 694.2 \text{ psi}$$

# Example

top chord 2x10 – bending + compression

Hem-Fir No.1 & Better

$$F_b = 1100 \text{ psi}$$

$$F_c = 1350 \text{ psi}$$

$$E_{min} = 550000 \text{ psi}$$

- Determine **allowable** stresses using applicable factors:

(compression: D+S)

$$F'_c = F_c (C_D C_F C_P) \quad f_c$$

$$F'_c = 1350 (1.15 \underset{SL}{1.0} \underset{BRACED}{0.897}) = 1392.7 \text{ psi} > 357.5$$

(flexure: D+S)

$$F'_b = F_b (C_D C_L C_F) \quad f_b$$

$$F'_b = 1100 (1.15 \underset{SL}{1.0} \underset{BRACED}{1.1}) = 1392 \text{ psi} > 694.2$$

strong axis buckling

$C_P$

$$l_e = 8.385' \quad d = 9.25''$$

$$l_e/d = \frac{8.385(12)}{9.25} = 10.88$$

$$F_{cE} = \frac{0.822 E_{min}}{(l_e/d)^2} = \frac{0.822(550000)}{10.88^2} = 3820 \text{ psi}$$

$$F_c^* = 1350 (1.15 \underset{SL}{1.0}) = 1552.5 \text{ psi}$$

$$F_{cE}/F_c^* = \frac{3820}{1552} = 2.46 \quad \alpha = 0.8$$

$$C_P = 0.897$$

Size Factors,  $C_F$

Grades	Width (depth)	Thickness (breadth)		$F_t$	$F_c$
		2" & 3"	4"		
		2", 3", & 4"	1.5		
Select	5"	1.4	1.4	1.4	1.1
Structural,	6"	1.3	1.3	1.3	1.1
No.1 & Btr,	8"	1.2	1.3	1.2	1.05
No.1, No.2,	10"	1.1	1.2	1.1	1.0
No.3	12"	1.0	1.1	1.0	1.0

$C_L$

The top chord is braced by the plywood sheathing so  $C_L = 1.0$

# Example

top chord 2x10

Eq. 3.9-3

$$\left[ \frac{f_c}{F'_c} \right]^2 + \frac{f_{b1}}{F'_{b1} [1 - (f_c/F_{cE1})]} \leq 1.0$$

COMP. + FLEXURE X-X

where:

$$f_c < F_{cE1} = \frac{0.822 E_{min}}{(l_{e1}/d_1)^2} \quad \text{EULER 1}$$

for either uniaxial edge-wise bending or biaxial bending

and

$$f_c < F_{cE2} = \frac{0.822 E_{min}}{(l_{e2}/d_2)^2} \quad \text{EULER 2}$$

for uniaxial flatwise bending or biaxial bending

and

$$f_{b1} < F_{bE} = \frac{1.20 E_{min}}{(R_B)^2} \quad \text{LTB}$$

for biaxial bending

$f_{b1}$  = actual edgewise bending stress (bending load applied to narrow face of member)

$f_{b2}$  = actual flatwise bending stress (bending load applied to wide face of member)

$d_1$  = wide face dimension (see Figure 3H)

$d_2$  = narrow face dimension (see Figure 3H)

COMPRESSION:

$$\left[ \frac{f_c}{F'_c} \right]^2 = \left[ \frac{357.5}{1392.7} \right]^2 = 0.0659$$

FLEXURE:

$$\frac{f_{b1}}{F'_{b1}} = \frac{694.2}{1392} = 0.4987$$

AMPLIFICATION FACTOR:

$$\frac{1}{1 - (357.5/3820)} = \frac{1}{0.906}$$

$$0.4987 (1.103) = 0.550$$

COMBINATION:

$$0.0659 + 0.550 = 0.616$$

$$0.616 < 1.0 \quad \checkmark \text{ PASS}$$

# Combined Stress in NDS

## Stud wall example

Exterior stud wall under bending + axial compression

1. Determine load per stud
2. Use axial load and moment to find actual stresses  $f_c$  and  $f_b$
3. Determine load factors
4. Calculate factored stresses
5. Check NDS equation 3.9-3

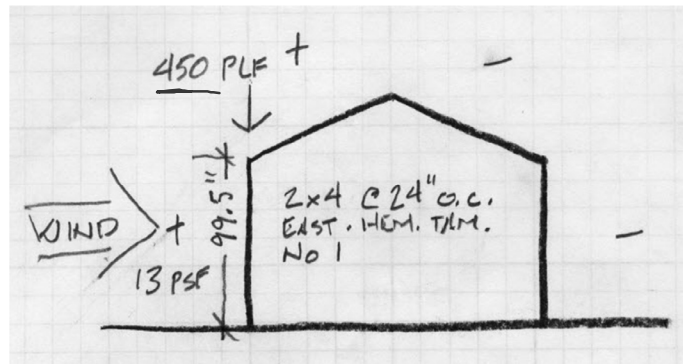

$$\frac{\left(\frac{f_c}{F'_c}\right)^2 + \frac{f_{b1}}{F_{b1} \left[1 - \left(\frac{f_c}{F_{cE1}}\right)\right]}}{\text{and } \frac{f_c}{F_{cE2}} + \frac{f_{b1}}{F_{bE}}} \leq 1.0 \quad (3.9-3)$$

and

$$\frac{f_c}{F_{cE2}} + \frac{f_{b1}}{F_{bE}} < 1.0 \quad (3.9-4)$$

~~flatwise bending~~

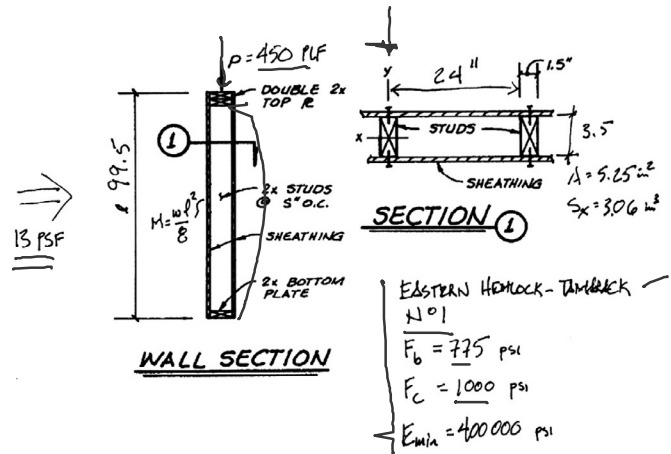

# Combined Stress in NDS

## stud wall

Exterior stud wall under bending + axial compression

1. Determine load per stud
2. Use axial load and moment to find actual stresses  $f_c$  and  $f_b$

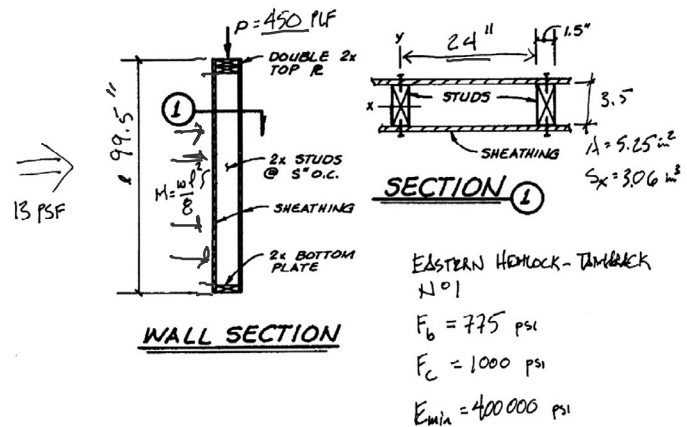

$$P = \text{LOAD/STUD}$$

$$P = 450 \text{ PLF} \frac{OC}{12} = 450 \frac{24}{12} = \boxed{900 \text{ LBS}} \checkmark$$

$$w = 13 \text{ PSF} \frac{OC}{12} = 13 \frac{24}{12} = \underline{26 \text{ PLF/STUD}}$$

$$M_x = \frac{w l^2}{8} = \frac{26 (99.5/12)^2}{8} = \boxed{223.4 \text{ !-}} \checkmark$$

$$f_c = \frac{P}{A} = \frac{900}{5.25 \times 2 \times 4} = \boxed{171.43 \text{ PSI}}$$

$$f_b = \frac{M}{S_x} = \frac{223.4 (12)}{3.06 \text{ in}^3} = \boxed{875.5 \text{ PSI}}$$

# Combined Stress in NDS

stud wall - bending

Exterior stud wall under bending + axial compression

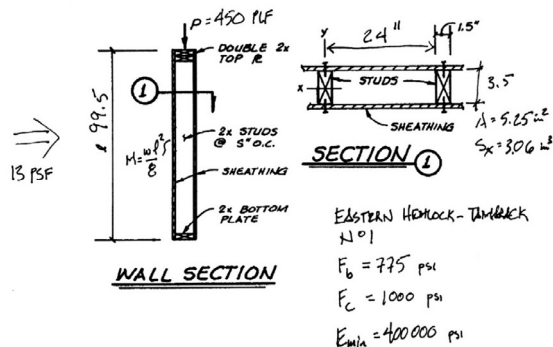

Size Factors,  $C_F$

Grades	Width (depth)	Thickness (breadth)		$F_t$	$F_c$
		2" & 3"	4"		
		2", 3", & 4"	1.5		
Select	5"	1.4	1.4	1.4	1.1
Structural,	6"	1.3	1.3	1.3	1.1
No. 1 & Btr,	8"	1.2	1.3	1.2	1.05
No. 1, No. 2,	10"	1.1	1.2	1.1	1.0
No. 3	12"	1.0	1.1	1.0	1.0

3. Determine load factors (bending)

TABULATED STRESS:

$F_b = 775 \text{ psi}$     $F_c = 1000 \text{ psi}$     $E_{min} = 400,000 \text{ psi}$

FACTORS:

$C_D = 1.6$  (WIND)  
 $C_F = 1.5$  (FOR  $F_b$ )    $1.15$  (FOR  $F_c$ )  
 $C_L = 1.0$  (BRACED BY SHEATHING)  
 $C_r = 1.15$  ( $\leq 24" \text{ o.c.}$ )

# Combined Stress in NDS

stud wall - bending

Exterior stud wall under bending + axial compression

4. Calculate factored stresses

$$F'_b = 775 \text{ psi}$$

$$C_D = 1.6$$

$$C_F = 1.5$$

$$C_M = 1.0$$

$$C_{Fu} = 1.0$$

$$C_t = 1.0$$

$$C_i = 1.0$$

$$C_L = 1.0$$

$$C_r = 1.15$$

Bending Stress

$$F'_b = 775 (1.6) (1.5) (1.15)$$

$$= 2139 \text{ psi}$$

## Combined Stress in NDS

stud wall - compression

Exterior stud wall under  
bending + axial compression

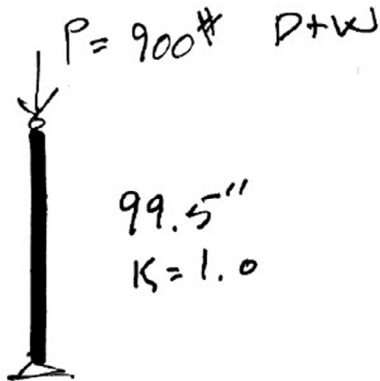

$$C_p = \frac{1 + (F_{CE}/F_c^*)}{2c} - \sqrt{\left[ \frac{1 + (F_{CE}/F_c^*)}{2c} \right]^2 - \frac{F_{CE}/F_c^*}{c}}$$

$C_p$  (strong axis)

$$F_c^* = 1000 \left( \frac{C_D}{1.6} \right) \left( \frac{C_F}{1.15} \right) = 1840$$

$$F_{CE} = \frac{0.822 \left( \frac{E_{min}}{400000} \right)}{(99.5/3.5)^2} = 406.8$$

$$c = 0.8$$

$$C_p = 0.21$$

- Determine load factors  
(compression - braced in weak axis)

## Combined Stress in NDS

stud wall - compression

Exterior stud wall under  
bending + axial compression

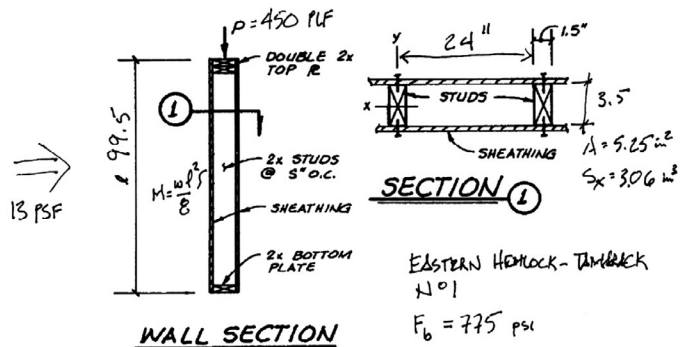

- Calculate factored stresses

$$F_c' = F_c (C_D C_F C_p)$$

$$C_D = 1.6 \quad \checkmark$$

$$C_F = 1.15 \quad \checkmark$$

$$C_p = 0.21 \quad \checkmark$$

Compression Stress

check  $f_c < F_c'$

(this should actually be checked  
for both W+D and D alone)

Actual Stress

$$f_c = \frac{P}{A} = \frac{900}{5.25} = 171.4 \text{ psi}$$

Factored Allowable Stress

$$F_c' = 1000 (1.6) (1.15) (0.21) = 386.4 \text{ psi}$$

EASTERN HEMLOCK-TIMBER  
#1

$$F_b = 775 \text{ psi}$$

$$F_c = 1000 \text{ psi}$$

$$E_{min} = 400000 \text{ psi}$$

# Combined Stress in NDS

stud wall – combined stress

Exterior stud wall under bending + axial compression

Combined Stress Calculation

$$\left[ \frac{f_c}{F_c'} \right]^2 + \frac{f_{b1}}{F_{b1}'} \frac{1}{1 - \left( \frac{f_c}{F_c' E I} \right)} \leq 1.0$$

AMPLIFICATION

$$\left[ \frac{171.4}{386.4} \right]^2 + \frac{876}{2139} \frac{1}{1 - \left( \frac{171.4}{406.8} \right)} =$$

$$0.1967 + (0.4095)(1.728) =$$

$$0.1967 + 0.7077 = \underline{0.9045} \leq 1.0 \checkmark \text{OK}$$

## Rafters

Flexure y-y + Axial Compression

Given:

S-P-F No.2 2x4 x 96"

$F_b = 875$  psi

$F_c = 1150$  psi  $E_{min} = 510000$  psi

$P = 45$  lbs.

Find: pass/fail

Find normal and axial components of the load.

Axial = 22.5 lbs

Normal = 39 lbs

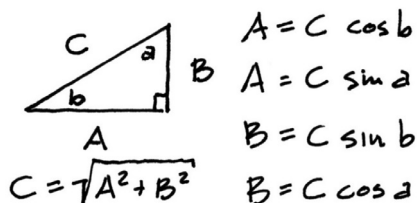

Francesco on 2x4

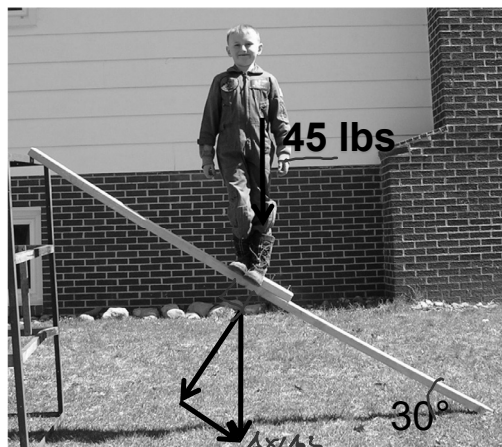

$L_v = 48"$

$L_h = 83.14"$

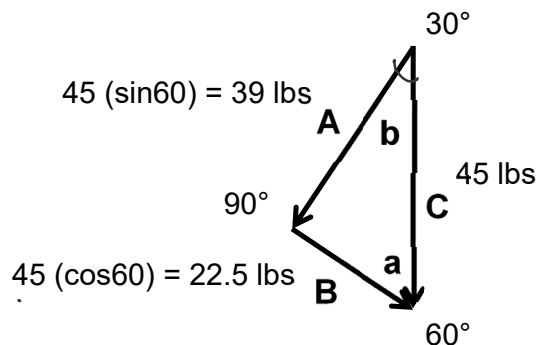

# Rafters

Flexure y-y + Axial Compression

Given:

S-P-F No.2 2x4 x 96"

$F_b = 875$  psi

$F_c = 1150$  psi  $E_{min} = 510000$  psi

$P = 45$  lbs. (as roof Lr)

Find: pass/fail

Axial = 22.5 lbs ✓

Normal = 39 lbs

Actual stress:

COMPRESSION:

$$f_c = \frac{P}{A} = \frac{22.5}{5.25} = 4.285 \text{ psi}$$

$$A = 5.25 \text{ in}^2$$

$$P = 22.5$$

Francesco on 2x4

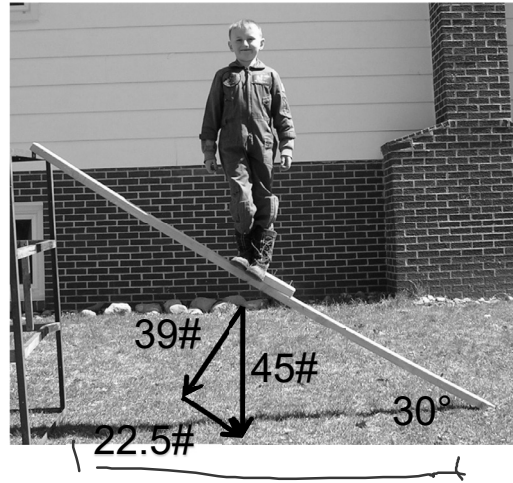

FLEXURE Y-Y

$$f_{b2} = \frac{M}{S_y} = \frac{936}{1.313} = 712.8 \text{ psi}$$

$$M = \frac{PL}{4} = \frac{39(96)}{4} = 936 \text{ in}\cdot\text{lb}$$

$$S_y = 1.313 \text{ in}^3$$

# Rafters

Flexure y-y + Axial Compression

S-P-F No.2 2x4 x 96"  $F_b = 875$  psi

$F_c = 1150$  psi  $E_{min} = 510000$  psi

Determine factored allowable stresses:

Compression

$$F_c' = F_c (C_D C_L C_F C_P)$$

$$F_c = 1150 \text{ psi}$$

$$C_D (L_r) = 1.25$$

$$C_F = 1.15$$

$$C_P = \frac{0.822 E_{min}}{(L_e/d)^2} = \frac{0.822 (510000)}{(96/1.5)^2} = 102.3 \text{ psi}$$

$$F_c^* = 1150 (1.25 \cdot 1.15) = 1653 \text{ psi}$$

$$F_c / F_c^* = \frac{102.3}{1653} = 0.06191$$

$$C_P = 0.0611 \quad C = 0.8$$

$$F_c' = 1150 (1.25 \cdot 1.15 \cdot 0.0611) = 101.0 \text{ psi}$$

Flat Use Factor,  $C_m$

Bending design values adjusted by size factors are based on edgewise use (load applied to narrow face). When dimension lumber is used flatwise (load applied to wide face), the bending design value,  $F_b$ , shall also be permitted to be multiplied by the following flat use factors:

Flat Use Factors,  $C_m$

Width (depth)	Thickness (breadth)	
	2" & 3"	4"
2" & 3"	1.0	—
4"	1.1	1.0
5"	1.1	1.05
6"	1.15	1.05
8"	1.15	1.05
10" & wider	1.2	1.1

Flexure y-y

$$F_{b2}' = F_b (C_D C_L C_F C_{Fu})$$

$$F_b = 875 \text{ psi}$$

$$C_D (L_r) = 1.25$$

$$C_F = 1.15$$

$$C_{Fu} = 1.1$$

$$C_L = 1.0$$

$$F_{b2}' = 875 (1.25 \cdot 1.0 \cdot 1.15 \cdot 1.1) = 1304.6 \text{ psi}$$

# Rafters

Flexure y-y + Axial Compression

Eq. 3.9-3

Check combination stresses:

- $f_c = 4.258 \text{ psi}$
- $F'_c = 101.0 \text{ psi}$
- $f_{b2} = 712.8 \text{ psi}$
- $F_{b2}' = 1804.6 \text{ psi}$
- $F_{CE2} = 102.3 \text{ psi}$

$$\left[ \frac{f_c}{F'_c} \right]^2 + \frac{f_{b2}}{F_{b2}' \left[ 1 - (f_c/F_{CE2}) - (f_{b1}/F_{bE})^2 \right]} \leq 1.0$$

COMP. + FLEXURE Y-Y

Compression:

COMPRESSION:

$$\left( \frac{f_c}{F'_c} \right)^2 = \left( \frac{4.255}{101.0} \right)^2 = \underline{\underline{0.00180}}$$

# Rafters

Flexure y-y + Axial Compression

$$\left[ \frac{f_c}{F'_c} \right]^2 + \frac{f_{b2}}{F_{b2}' \left[ 1 - (f_c/F_{CE2}) - (f_{b1}/F_{bE})^2 \right]} \leq 1.0$$

COMP. + FLEXURE Y-Y

Check combination stresses:

Flexure y-y

$$f_c = 4.255 \text{ psi}$$

$$F_{CE2} = 102.3 \text{ psi}$$

$$\frac{f_c}{F_{CE2}} = \frac{4.255}{102.3} = 0.04188$$

$$f_{b1} = \frac{M}{S_x} = \frac{0}{3.06} = 0$$

(in this example there is no strong axis bending, so the term is zero)

FLEXURE Y-Y

$$\frac{f_{b2}}{F_{b2}'} = \frac{712.8}{1804.6} = 0.395$$

AMPLIFICATION FACTOR: X-X AXIS

$$\frac{1}{1 - (f_c/F_{CE2}) - (f_{b1}/F_{bE})^2} = \frac{1}{1 - (4.255/102.3) - (0/F_{bE})^2} = \frac{1}{1 - 0.04188 - 0} = \frac{1}{0.95812} = 1.043$$

$$0.395(1.043) = 0.412 \checkmark < 1.0 \text{ OK}$$



## Rafters

Flexure y-y + Axial Compression

Check combination stresses:

Eq. 3.9-3

$$\left[ \frac{f_c}{F_c'} \right]^2 + \frac{f_{b2}}{F_{b2}' \left[ 1 - (f_c/F_{CE2}) - (f_{b1}/F_{bE})^2 \right]} \leq 1.0$$

COMP. + FLEXURE Y-Y

COMPRESSION + FLEXURE Y-Y

$$0.0018 + 0.412 = \underline{0.414}$$

$$0.414 < 1.0 \quad \checkmark \text{OK}$$

## Rafters

Flexure y-y + Axial Compression

Check combination stresses:

Eq. 3.9-4

EQ 3.9-4 FLATWISE BENDING

$$\frac{f_c}{F_{CE2}} + \left( \frac{f_{b1}}{F_{bE}} \right)^2 < 1.0$$
$$\frac{4.285}{102.3} + \left( \frac{0}{F_{bE}} \right)^2$$

$$0.0419 < 1.0 \quad \text{PASS} \quad \checkmark$$