

Mechanical Connections

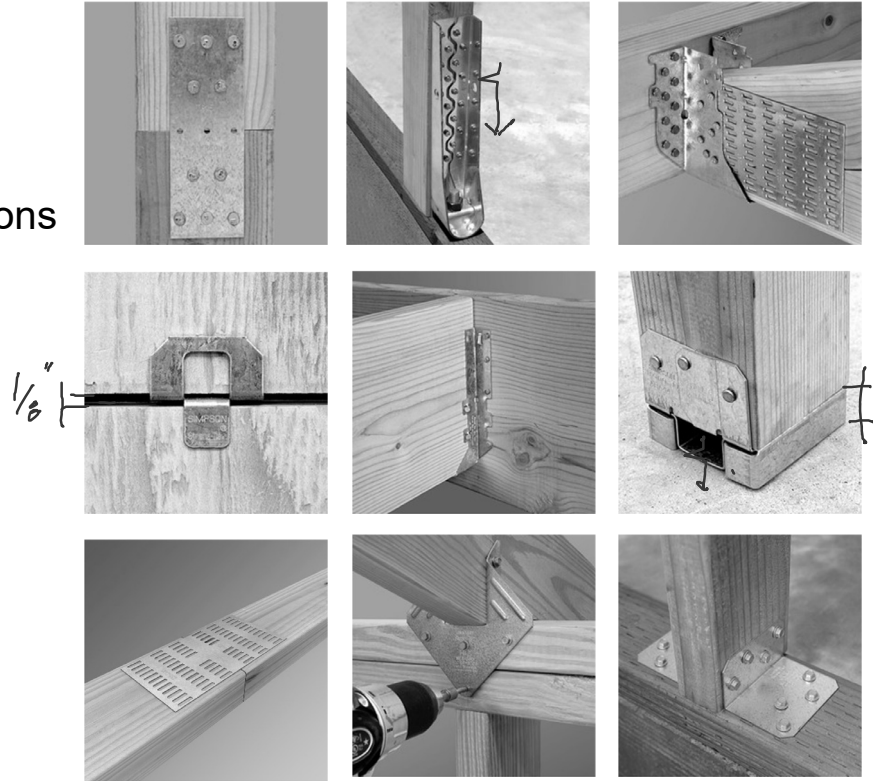

Connection Behavior

Strength

- transmits load

Ductility ✓

- gives warning
- absorbs energy

Design

- size ✓
- number ✓
- slenderness of fastener -
- spacing -
- end distance

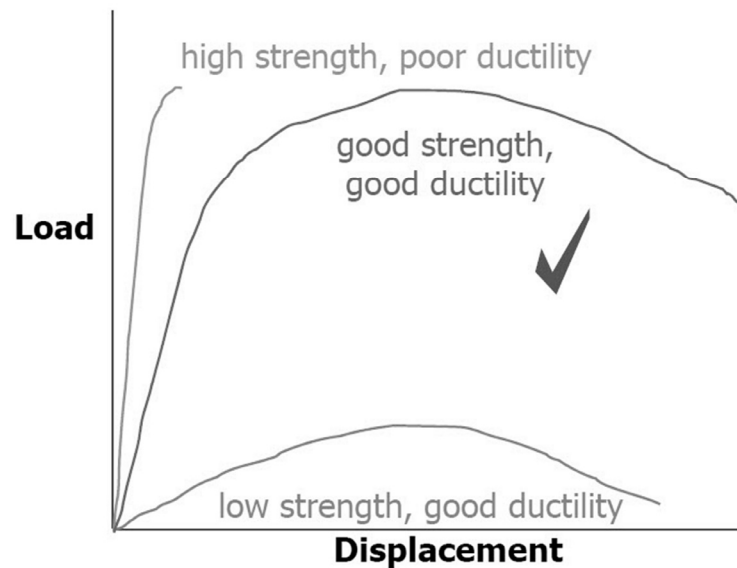

Connection Behavior

Nails

- low strength
- high ductility

Bolts

- high strength
- low ductility

Performance = strength + ductility

SPLIT RING

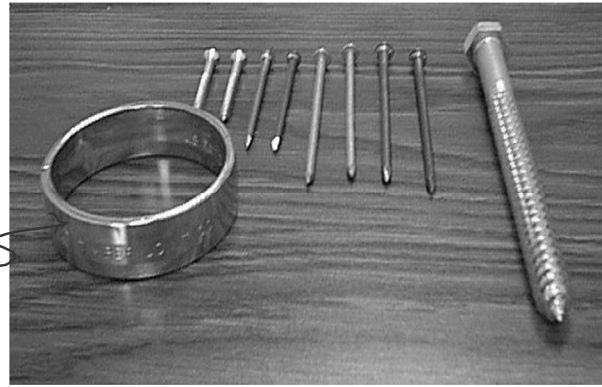

RIVETS

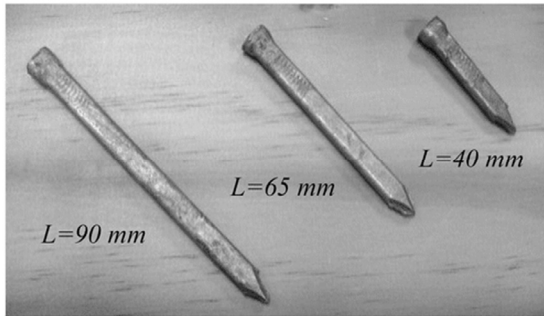

Connection Behavior

Wood Strength

- high parallel to grain
- low across the grain

End support is good



Connection Behavior

Spread the load on wood

- one large fastener – bad
- several small fasteners - good

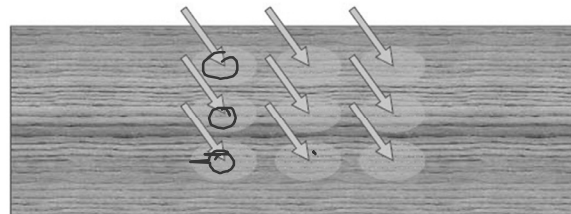
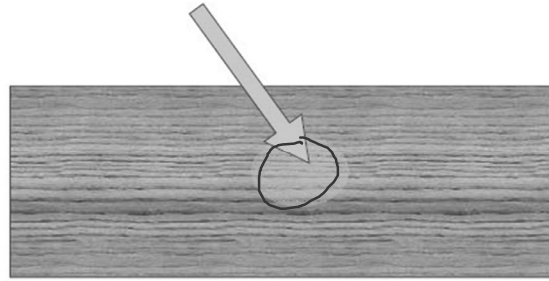

Connection Behavior

Single connector

- concentrates load
- splits wood or crush
- no redundancy

Multi-connectors

- spreads load
- less splitting
- more redundancy



Connection Behavior

Connectors that spread load

Hanger hardware



Connection Behavior

Truss gusset plate connectors



NDS 2018

Chapter 11

(general overview) FACTORS

Chapter 12

(nails, screws, bolts, and pins)

Chapter 13

(split ring & shear plate)

Chapter 14

(timber rivets)

NATIONAL DESIGN SPECIFICATION FOR WOOD CONSTRUCTION 63

MECHANICAL CONNECTIONS

11.1 General 64
 11.2 Reference Design Values 65
 11.3 Adjustment of Reference Design Values 65

Table 11.3.1 Applicability of Adjustment Factors for Connections 66
 Table 11.3.2 Wet Service Factors, C_M , for Connections 67
 Table 11.3.3 Temperature Factors, C_T , for Connections 67
 Table 11.3.4 Group Action Factors, C_g , for Bolt or Lag Screw Connections with Wood Side Members 69
 Table 11.3.5 Group Action Factors, C_g , for Split Ring or Shear Plate Connections with Wood Side Members 69
 Table 11.3.6 Group Action Factors, C_g , for Bolt or Lag Screw Connections with Steel Side Members 71
 Table 11.3.7 Group Action Factors, C_g , for Split Ring or Shear Plate Connections with Steel Side Members 71

11

NATIONAL DESIGN SPECIFICATION FOR WOOD CONSTRUCTION 73

DOWEL-TYPE FASTENERS (BOLTS, LAG SCREWS, WOOD SCREWS, NAILS/SPIKES, DRIFT BOLTS, AND DRIFT PINS)

12.1 General 74
 12.2 Reference Withdrawal Design Values 76
 12.3 Reference Lateral Design Values 83
 12.4 Combined Lateral and Withdrawal Loads 89
 12.5 Adjustment of Reference Design Values 89

12.6 Multiple Fasteners 89
 Table 12.6.1 Edge-Nail Reference Withdrawal Design Values 89
 Table 12.6.2 End-Nail Reference Withdrawal Design Values 89
 Table 12.6.3 Split-Ring Through, W_s 89
 Table 12.6.4 Split-Ring Spacing, S 89
 Table 12.6.5 Reference Area, A_p 89
 Table 12.6.6 Split-Ring Spacing, S , for Dowel-Type Fasteners in 89
 Table 12.6.7 Adjusted Nails Capacity 89
 Table 12.6.8 Shear Withdrawal Strength for Nail Fasteners Parallel to Grain 89
 Table 12.6.9 End Grain Withdrawal Strength 89
 Table 12.6.10 End Grain Withdrawal Strength for Fasteners Parallel to Grain 89
 Table 12.6.11 Spacing Requirements for Fasteners in Shear 89
 Table 12.6.12 Spacing Requirements Between Rows 89
 Table 12.6.13 Edge and End Grain Spacing Requirements 89
 Table 12.6.14 End Grain Spacing Requirements 89
 Table 12.6.15 End Grain Spacing Requirements for Fasteners Parallel to Grain 89
 Table 12.6.16 Spacing Requirements for Fasteners Parallel to Grain 89
 Table 12.6.17 Spacing Requirements for Fasteners Parallel to Grain 89
 Table 12.6.18 Spacing Requirements for Fasteners Parallel to Grain 89
 Table 12.6.19 Spacing Requirements for Fasteners Parallel to Grain 89
 Table 12.6.20 Spacing Requirements for Fasteners Parallel to Grain 89
 Table 12.6.21 Spacing Requirements for Fasteners Parallel to Grain 89
 Table 12.6.22 Spacing Requirements for Fasteners Parallel to Grain 89
 Table 12.6.23 Spacing Requirements for Fasteners Parallel to Grain 89
 Table 12.6.24 Spacing Requirements for Fasteners Parallel to Grain 89
 Table 12.6.25 Spacing Requirements for Fasteners Parallel to Grain 89
 Table 12.6.26 Spacing Requirements for Fasteners Parallel to Grain 89
 Table 12.6.27 Spacing Requirements for Fasteners Parallel to Grain 89
 Table 12.6.28 Spacing Requirements for Fasteners Parallel to Grain 89
 Table 12.6.29 Spacing Requirements for Fasteners Parallel to Grain 89
 Table 12.6.30 Spacing Requirements for Fasteners Parallel to Grain 89
 Table 12.6.31 Spacing Requirements for Fasteners Parallel to Grain 89
 Table 12.6.32 Spacing Requirements for Fasteners Parallel to Grain 89
 Table 12.6.33 Spacing Requirements for Fasteners Parallel to Grain 89
 Table 12.6.34 Spacing Requirements for Fasteners Parallel to Grain 89
 Table 12.6.35 Spacing Requirements for Fasteners Parallel to Grain 89
 Table 12.6.36 Spacing Requirements for Fasteners Parallel to Grain 89
 Table 12.6.37 Spacing Requirements for Fasteners Parallel to Grain 89
 Table 12.6.38 Spacing Requirements for Fasteners Parallel to Grain 89
 Table 12.6.39 Spacing Requirements for Fasteners Parallel to Grain 89
 Table 12.6.40 Spacing Requirements for Fasteners Parallel to Grain 89
 Table 12.6.41 Spacing Requirements for Fasteners Parallel to Grain 89
 Table 12.6.42 Spacing Requirements for Fasteners Parallel to Grain 89
 Table 12.6.43 Spacing Requirements for Fasteners Parallel to Grain 89
 Table 12.6.44 Spacing Requirements for Fasteners Parallel to Grain 89
 Table 12.6.45 Spacing Requirements for Fasteners Parallel to Grain 89
 Table 12.6.46 Spacing Requirements for Fasteners Parallel to Grain 89
 Table 12.6.47 Spacing Requirements for Fasteners Parallel to Grain 89
 Table 12.6.48 Spacing Requirements for Fasteners Parallel to Grain 89
 Table 12.6.49 Spacing Requirements for Fasteners Parallel to Grain 89
 Table 12.6.50 Spacing Requirements for Fasteners Parallel to Grain 89
 Table 12.6.51 Spacing Requirements for Fasteners Parallel to Grain 89
 Table 12.6.52 Spacing Requirements for Fasteners Parallel to Grain 89
 Table 12.6.53 Spacing Requirements for Fasteners Parallel to Grain 89
 Table 12.6.54 Spacing Requirements for Fasteners Parallel to Grain 89
 Table 12.6.55 Spacing Requirements for Fasteners Parallel to Grain 89
 Table 12.6.56 Spacing Requirements for Fasteners Parallel to Grain 89
 Table 12.6.57 Spacing Requirements for Fasteners Parallel to Grain 89
 Table 12.6.58 Spacing Requirements for Fasteners Parallel to Grain 89
 Table 12.6.59 Spacing Requirements for Fasteners Parallel to Grain 89
 Table 12.6.60 Spacing Requirements for Fasteners Parallel to Grain 89
 Table 12.6.61 Spacing Requirements for Fasteners Parallel to Grain 89
 Table 12.6.62 Spacing Requirements for Fasteners Parallel to Grain 89
 Table 12.6.63 Spacing Requirements for Fasteners Parallel to Grain 89
 Table 12.6.64 Spacing Requirements for Fasteners Parallel to Grain 89
 Table 12.6.65 Spacing Requirements for Fasteners Parallel to Grain 89
 Table 12.6.66 Spacing Requirements for Fasteners Parallel to Grain 89
 Table 12.6.67 Spacing Requirements for Fasteners Parallel to Grain 89
 Table 12.6.68 Spacing Requirements for Fasteners Parallel to Grain 89
 Table 12.6.69 Spacing Requirements for Fasteners Parallel to Grain 89
 Table 12.6.70 Spacing Requirements for Fasteners Parallel to Grain 89
 Table 12.6.71 Spacing Requirements for Fasteners Parallel to Grain 89
 Table 12.6.72 Spacing Requirements for Fasteners Parallel to Grain 89
 Table 12.6.73 Spacing Requirements for Fasteners Parallel to Grain 89
 Table 12.6.74 Spacing Requirements for Fasteners Parallel to Grain 89
 Table 12.6.75 Spacing Requirements for Fasteners Parallel to Grain 89
 Table 12.6.76 Spacing Requirements for Fasteners Parallel to Grain 89
 Table 12.6.77 Spacing Requirements for Fasteners Parallel to Grain 89
 Table 12.6.78 Spacing Requirements for Fasteners Parallel to Grain 89
 Table 12.6.79 Spacing Requirements for Fasteners Parallel to Grain 89
 Table 12.6.80 Spacing Requirements for Fasteners Parallel to Grain 89
 Table 12.6.81 Spacing Requirements for Fasteners Parallel to Grain 89
 Table 12.6.82 Spacing Requirements for Fasteners Parallel to Grain 89
 Table 12.6.83 Spacing Requirements for Fasteners Parallel to Grain 89
 Table 12.6.84 Spacing Requirements for Fasteners Parallel to Grain 89
 Table 12.6.85 Spacing Requirements for Fasteners Parallel to Grain 89
 Table 12.6.86 Spacing Requirements for Fasteners Parallel to Grain 89
 Table 12.6.87 Spacing Requirements for Fasteners Parallel to Grain 89
 Table 12.6.88 Spacing Requirements for Fasteners Parallel to Grain 89
 Table 12.6.89 Spacing Requirements for Fasteners Parallel to Grain 89
 Table 12.6.90 Spacing Requirements for Fasteners Parallel to Grain 89
 Table 12.6.91 Spacing Requirements for Fasteners Parallel to Grain 89
 Table 12.6.92 Spacing Requirements for Fasteners Parallel to Grain 89
 Table 12.6.93 Spacing Requirements for Fasteners Parallel to Grain 89
 Table 12.6.94 Spacing Requirements for Fasteners Parallel to Grain 89
 Table 12.6.95 Spacing Requirements for Fasteners Parallel to Grain 89
 Table 12.6.96 Spacing Requirements for Fasteners Parallel to Grain 89
 Table 12.6.97 Spacing Requirements for Fasteners Parallel to Grain 89
 Table 12.6.98 Spacing Requirements for Fasteners Parallel to Grain 89
 Table 12.6.99 Spacing Requirements for Fasteners Parallel to Grain 89
 Table 12.6.100 Spacing Requirements for Fasteners Parallel to Grain 89

12

NATIONAL DESIGN SPECIFICATION FOR WOOD CONSTRUCTION 119

SPLIT RING AND SHEAR PLATE CONNECTORS

13.1 General 120
 13.2 Reference Design Values 121
 13.3 Placement of Split Ring and Shear Plate Connectors 127

Table 13.3.1 Spacing Groups for Split Ring and Shear Plate Connectors 127
 Table 13.3.2 Split Ring Connector Load Reference Design Values 127
 Table 13.3.3 Shear Plate Connector Load Reference Design Values 127
 Table 13.3.4 Penetration Depth Factors, C_d , for Split Ring and Shear Plate Connectors Loaded Parallel to Grain 127
 Table 13.3.5 Metal Side Plate Factors, C_{sp} , for Split Ring and Shear Plate Connectors Loaded Parallel to Grain 127
 Table 13.3.6 Factors for Determining Minimum Spacing Along Splitting Edge, C_{se} , 2.4.1 127
 Table 13.3.7 Factors for Determining Minimum Spacing Along Splitting Edge, C_{se} , 2.4.2 127
 Table 13.3.8 Factors for Determining Minimum Spacing Along Splitting Edge, C_{se} , 2.4.3 127
 Table 13.3.9 Factors for Determining Minimum Spacing Along Splitting Edge, C_{se} , 2.4.4 127
 Table 13.3.10 Factors for Determining Minimum Spacing Along Splitting Edge, C_{se} , 2.4.5 127
 Table 13.3.11 Factors for Determining Minimum Spacing Along Splitting Edge, C_{se} , 2.4.6 127
 Table 13.3.12 Factors for Determining Minimum Spacing Along Splitting Edge, C_{se} , 2.4.7 127
 Table 13.3.13 Factors for Determining Minimum Spacing Along Splitting Edge, C_{se} , 2.4.8 127
 Table 13.3.14 Factors for Determining Minimum Spacing Along Splitting Edge, C_{se} , 2.4.9 127
 Table 13.3.15 Factors for Determining Minimum Spacing Along Splitting Edge, C_{se} , 2.4.10 127
 Table 13.3.16 Factors for Determining Minimum Spacing Along Splitting Edge, C_{se} , 2.4.11 127
 Table 13.3.17 Factors for Determining Minimum Spacing Along Splitting Edge, C_{se} , 2.4.12 127
 Table 13.3.18 Factors for Determining Minimum Spacing Along Splitting Edge, C_{se} , 2.4.13 127
 Table 13.3.19 Factors for Determining Minimum Spacing Along Splitting Edge, C_{se} , 2.4.14 127
 Table 13.3.20 Factors for Determining Minimum Spacing Along Splitting Edge, C_{se} , 2.4.15 127
 Table 13.3.21 Factors for Determining Minimum Spacing Along Splitting Edge, C_{se} , 2.4.16 127
 Table 13.3.22 Factors for Determining Minimum Spacing Along Splitting Edge, C_{se} , 2.4.17 127
 Table 13.3.23 Factors for Determining Minimum Spacing Along Splitting Edge, C_{se} , 2.4.18 127
 Table 13.3.24 Factors for Determining Minimum Spacing Along Splitting Edge, C_{se} , 2.4.19 127
 Table 13.3.25 Factors for Determining Minimum Spacing Along Splitting Edge, C_{se} , 2.4.20 127
 Table 13.3.26 Factors for Determining Minimum Spacing Along Splitting Edge, C_{se} , 2.4.21 127
 Table 13.3.27 Factors for Determining Minimum Spacing Along Splitting Edge, C_{se} , 2.4.22 127
 Table 13.3.28 Factors for Determining Minimum Spacing Along Splitting Edge, C_{se} , 2.4.23 127
 Table 13.3.29 Factors for Determining Minimum Spacing Along Splitting Edge, C_{se} , 2.4.24 127
 Table 13.3.30 Factors for Determining Minimum Spacing Along Splitting Edge, C_{se} , 2.4.25 127
 Table 13.3.31 Factors for Determining Minimum Spacing Along Splitting Edge, C_{se} , 2.4.26 127
 Table 13.3.32 Factors for Determining Minimum Spacing Along Splitting Edge, C_{se} , 2.4.27 127
 Table 13.3.33 Factors for Determining Minimum Spacing Along Splitting Edge, C_{se} , 2.4.28 127
 Table 13.3.34 Factors for Determining Minimum Spacing Along Splitting Edge, C_{se} , 2.4.29 127
 Table 13.3.35 Factors for Determining Minimum Spacing Along Splitting Edge, C_{se} , 2.4.30 127
 Table 13.3.36 Factors for Determining Minimum Spacing Along Splitting Edge, C_{se} , 2.4.31 127
 Table 13.3.37 Factors for Determining Minimum Spacing Along Splitting Edge, C_{se} , 2.4.32 127
 Table 13.3.38 Factors for Determining Minimum Spacing Along Splitting Edge, C_{se} , 2.4.33 127
 Table 13.3.39 Factors for Determining Minimum Spacing Along Splitting Edge, C_{se} , 2.4.34 127
 Table 13.3.40 Factors for Determining Minimum Spacing Along Splitting Edge, C_{se} , 2.4.35 127
 Table 13.3.41 Factors for Determining Minimum Spacing Along Splitting Edge, C_{se} , 2.4.36 127
 Table 13.3.42 Factors for Determining Minimum Spacing Along Splitting Edge, C_{se} , 2.4.37 127
 Table 13.3.43 Factors for Determining Minimum Spacing Along Splitting Edge, C_{se} , 2.4.38 127
 Table 13.3.44 Factors for Determining Minimum Spacing Along Splitting Edge, C_{se} , 2.4.39 127
 Table 13.3.45 Factors for Determining Minimum Spacing Along Splitting Edge, C_{se} , 2.4.40 127
 Table 13.3.46 Factors for Determining Minimum Spacing Along Splitting Edge, C_{se} , 2.4.41 127
 Table 13.3.47 Factors for Determining Minimum Spacing Along Splitting Edge, C_{se} , 2.4.42 127
 Table 13.3.48 Factors for Determining Minimum Spacing Along Splitting Edge, C_{se} , 2.4.43 127
 Table 13.3.49 Factors for Determining Minimum Spacing Along Splitting Edge, C_{se} , 2.4.44 127
 Table 13.3.50 Factors for Determining Minimum Spacing Along Splitting Edge, C_{se} , 2.4.45 127
 Table 13.3.51 Factors for Determining Minimum Spacing Along Splitting Edge, C_{se} , 2.4.46 127
 Table 13.3.52 Factors for Determining Minimum Spacing Along Splitting Edge, C_{se} , 2.4.47 127
 Table 13.3.53 Factors for Determining Minimum Spacing Along Splitting Edge, C_{se} , 2.4.48 127
 Table 13.3.54 Factors for Determining Minimum Spacing Along Splitting Edge, C_{se} , 2.4.49 127
 Table 13.3.55 Factors for Determining Minimum Spacing Along Splitting Edge, C_{se} , 2.4.50 127
 Table 13.3.56 Factors for Determining Minimum Spacing Along Splitting Edge, C_{se} , 2.4.51 127
 Table 13.3.57 Factors for Determining Minimum Spacing Along Splitting Edge, C_{se} , 2.4.52 127
 Table 13.3.58 Factors for Determining Minimum Spacing Along Splitting Edge, C_{se} , 2.4.53 127
 Table 13.3.59 Factors for Determining Minimum Spacing Along Splitting Edge, C_{se} , 2.4.54 127
 Table 13.3.60 Factors for Determining Minimum Spacing Along Splitting Edge, C_{se} , 2.4.55 127
 Table 13.3.61 Factors for Determining Minimum Spacing Along Splitting Edge, C_{se} , 2.4.56 127
 Table 13.3.62 Factors for Determining Minimum Spacing Along Splitting Edge, C_{se} , 2.4.57 127
 Table 13.3.63 Factors for Determining Minimum Spacing Along Splitting Edge, C_{se} , 2.4.58 127
 Table 13.3.64 Factors for Determining Minimum Spacing Along Splitting Edge, C_{se} , 2.4.59 127
 Table 13.3.65 Factors for Determining Minimum Spacing Along Splitting Edge, C_{se} , 2.4.60 127
 Table 13.3.66 Factors for Determining Minimum Spacing Along Splitting Edge, C_{se} , 2.4.61 127
 Table 13.3.67 Factors for Determining Minimum Spacing Along Splitting Edge, C_{se} , 2.4.62 127
 Table 13.3.68 Factors for Determining Minimum Spacing Along Splitting Edge, C_{se} , 2.4.63 127
 Table 13.3.69 Factors for Determining Minimum Spacing Along Splitting Edge, C_{se} , 2.4.64 127
 Table 13.3.70 Factors for Determining Minimum Spacing Along Splitting Edge, C_{se} , 2.4.65 127
 Table 13.3.71 Factors for Determining Minimum Spacing Along Splitting Edge, C_{se} , 2.4.66 127
 Table 13.3.72 Factors for Determining Minimum Spacing Along Splitting Edge, C_{se} , 2.4.67 127
 Table 13.3.73 Factors for Determining Minimum Spacing Along Splitting Edge, C_{se} , 2.4.68 127
 Table 13.3.74 Factors for Determining Minimum Spacing Along Splitting Edge, C_{se} , 2.4.69 127
 Table 13.3.75 Factors for Determining Minimum Spacing Along Splitting Edge, C_{se} , 2.4.70 127
 Table 13.3.76 Factors for Determining Minimum Spacing Along Splitting Edge, C_{se} , 2.4.71 127
 Table 13.3.77 Factors for Determining Minimum Spacing Along Splitting Edge, C_{se} , 2.4.72 127
 Table 13.3.78 Factors for Determining Minimum Spacing Along Splitting Edge, C_{se} , 2.4.73 127
 Table 13.3.79 Factors for Determining Minimum Spacing Along Splitting Edge, C_{se} , 2.4.74 127
 Table 13.3.80 Factors for Determining Minimum Spacing Along Splitting Edge, C_{se} , 2.4.75 127
 Table 13.3.81 Factors for Determining Minimum Spacing Along Splitting Edge, C_{se} , 2.4.76 127
 Table 13.3.82 Factors for Determining Minimum Spacing Along Splitting Edge, C_{se} , 2.4.77 127
 Table 13.3.83 Factors for Determining Minimum Spacing Along Splitting Edge, C_{se} , 2.4.78 127
 Table 13.3.84 Factors for Determining Minimum Spacing Along Splitting Edge, C_{se} , 2.4.79 127
 Table 13.3.85 Factors for Determining Minimum Spacing Along Splitting Edge, C_{se} , 2.4.80 127
 Table 13.3.86 Factors for Determining Minimum Spacing Along Splitting Edge, C_{se} , 2.4.81 127
 Table 13.3.87 Factors for Determining Minimum Spacing Along Splitting Edge, C_{se} , 2.4.82 127
 Table 13.3.88 Factors for Determining Minimum Spacing Along Splitting Edge, C_{se} , 2.4.83 127
 Table 13.3.89 Factors for Determining Minimum Spacing Along Splitting Edge, C_{se} , 2.4.84 127
 Table 13.3.90 Factors for Determining Minimum Spacing Along Splitting Edge, C_{se} , 2.4.85 127
 Table 13.3.91 Factors for Determining Minimum Spacing Along Splitting Edge, C_{se} , 2.4.86 127
 Table 13.3.92 Factors for Determining Minimum Spacing Along Splitting Edge, C_{se} , 2.4.87 127
 Table 13.3.93 Factors for Determining Minimum Spacing Along Splitting Edge, C_{se} , 2.4.88 127
 Table 13.3.94 Factors for Determining Minimum Spacing Along Splitting Edge, C_{se} , 2.4.89 127
 Table 13.3.95 Factors for Determining Minimum Spacing Along Splitting Edge, C_{se} , 2.4.90 127
 Table 13.3.96 Factors for Determining Minimum Spacing Along Splitting Edge, C_{se} , 2.4.91 127
 Table 13.3.97 Factors for Determining Minimum Spacing Along Splitting Edge, C_{se} , 2.4.92 127
 Table 13.3.98 Factors for Determining Minimum Spacing Along Splitting Edge, C_{se} , 2.4.93 127
 Table 13.3.99 Factors for Determining Minimum Spacing Along Splitting Edge, C_{se} , 2.4.94 127
 Table 13.3.100 Factors for Determining Minimum Spacing Along Splitting Edge, C_{se} , 2.4.95 127

13

NATIONAL DESIGN SPECIFICATION FOR WOOD CONSTRUCTION 123

TIMBER RIVETS

14.1 General 124
 14.2 Reference Design Values 124
 14.3 Placement of Timber Rivets 126

Table 14.2.1 Metal Side Plate Factors, C_{sp} , for Timber Rivet Connections 126
 Table 14.2.2 Minimum End and Edge Distances for Timber Rivet Joints 126
 Table 14.2.3 A-F Reference Wood Capacity Design Values Parallel to Grain, P_{ref} , for Timber Rivets 126
 A - Rivet Length = 3.5", $s_p = 1.5"$, $s_e = 1"$ 126
 B - Rivet Length = 3.5", $s_p = 1.5"$, $s_e = 1"$ 126
 C - Rivet Length = 3.5", $s_p = 1.5"$, $s_e = 1"$ 126
 D - Rivet Length = 3.5", $s_p = 1.5"$, $s_e = 1"$ 126
 E - Rivet Length = 3.5", $s_p = 1.5"$, $s_e = 1"$ 126
 F - Rivet Length = 3.5", $s_p = 1.5"$, $s_e = 1"$ 126
 Table 14.2.4 Values of q_{\parallel} (lb) Perpendicular to Grain for Timber Rivets 126
 Table 14.2.5 Geometry Factors, C_g , for Timber Rivet Connections Loaded Perpendicular to Grain 126

14

Peter von Buelow

University of Michigan, TCAUP

Slide 9 of 56

NDS 2018 - Chapter 11

Table 11.3.1 Applicability of Adjustment Factors for Connections

service factors

	ASD Only	ASD and LRFD										LRFD Only		
		Load Duration Factor ¹	Wet Service Factor	Temperature Factor	Group Action Factor	Geometry Factor ³	Penetration Depth Factor ³	End Grain Factor ³	Metal Side Plate Factor ³	Diaphragm Factor ³	Toe-Nail Factor ³	Format Conversion Factor	Resistance Factor	Time Effect Factor
		C_D	C_M	C_T	C_g	C_{Δ}	-	C_{eg}	-	C_{di}	C_{tn}	K_F	ϕ	
Lateral Loads														
Dowel-type Fasteners (e.g. bolts, lag screws, wood screws, nails, spikes, drift bolts, & drift pins)	$Z' = Z \times$	C_D	C_M	C_T	C_g	C_{Δ}	-	C_{eg}	-	C_{di}	C_{tn}	3.32	0.65	λ
Split Ring and Shear Plate Connectors	$P = P \times$	C_D	C_M	C_T	C_g	C_{Δ}	C_d	-	C_{st}	-	-	3.32	0.65	λ
	$Q = Q \times$	C_D	C_M	C_T	C_g	C_{Δ}	C_d	-	-	-	-	3.32	0.65	λ
Timber Rivets	$P = P \times$	C_D	C_M	C_T	-	-	-	-	C_{st}^4	-	-	3.32	0.65	λ
	$Q = Q \times$	C_D	C_M	C_T	-	-	-	-	C_{st}^4	-	-	3.32	0.65	λ
Spike Grids	$Z' = Z \times$	C_D	C_M	C_T	-	C_{Δ}	-	-	-	-	-	3.32	0.65	λ
Withdrawal Loads														
Nails, spikes, lag screws, wood screws, & drift pins	$W' = W \times$	C_D	C_M^2	C_T	-	-	-	C_{eg}	-	-	C_{tn}	3.32	0.65	λ
Pull-Through														
Fasteners with Round Heads	$W'_H = W_H \times$	C_D	C_M	C_T	-	-	-	-	-	-	-	3.32	0.65	λ

1. The load duration factor, C_D , shall not exceed 1.6 for connections (see 11.3.2).
2. The wet service factor, C_M , shall not apply to toe-nails loaded in withdrawal (see 12.5.4.1).
3. Specific information concerning geometry factors C_{Δ} , penetration depth factors C_d , end grain factors, C_{eg} , metal side plate factors, C_{sp} , diaphragm factors, C_{di} , and toe-nail factors, C_{tn} , is provided in Chapters 12, 13, and 14.
4. The metal side plate factor, C_{sp} , is only applied when rivet capacity (P_r , Q_r) controls (see Chapter 14).
5. The geometry factor, C_{Δ} , is only applied when wood capacity, Q_{sw} , controls (see Chapter 14).

Peter von Buelow

University of Michigan, TCAUP

Slide 10 of 56

service factors

- C_D
- C_t

11.3.2 Load Duration Factor, C_D (ASD Only)

Reference design values shall be multiplied by the load duration factors, $C_D \leq 1.6$, specified in 2.3.2 and Appendix B, except when the capacity of the connection is controlled by metal strength or strength of concrete/masonry (see 11.2.3, 11.2.4, and Appendix B.3). The impact load duration factor shall not apply to connections.

11.3.4 Temperature Factor, C_t

Reference design values shall be multiplied by the temperature factors, C_t , in Table 11.3.4 for connections that will experience sustained exposure to elevated temperatures up to 150°F (see Appendix C).

Table 11.3.4 Temperature Factors, C_t , for Connections

In-Service Moisture Conditions ¹	C_t		
	$T \leq 100^\circ\text{F}$	$100^\circ\text{F} < T \leq 125^\circ\text{F}$	$125^\circ\text{F} < T \leq 150^\circ\text{F}$
Dry	1.0	0.8	0.7
Wet	1.0	0.7	0.5

1. Wet and dry service conditions for connections are specified in 11.3.3.

service factors

- C_M

Table 11.3.3 Wet Service Factors, C_M , for Connections

Fastener Type	Moisture Content		C_M
	At Time of Fabrication	In-Service	
<u>Lateral Loads</u>			
Split Ring and Shear Plate Connectors ¹	$\leq 19\%$	$\leq 19\%$	1.0
	$> 19\%$	$\leq 19\%$	0.8
	any	$> 19\%$	0.7
Dowel-type Fasteners (e.g. bolts, lag screws, wood screws, nails, spikes, drift bolts, & drift pins)	$\leq 19\%$ <i>DRY</i>	$\leq 19\%$ <i>DRY</i>	1.0 <i>1.0</i>
	$> 19\%$ <i>WET</i>	$\leq 19\%$ <i>DRY</i>	0.8 <i>0.8</i>
	any <i>WET</i>	$> 19\%$ <i>WET</i>	0.7 <i>0.7</i>
Timber Rivets	$\leq 19\%$	$\leq 19\%$	1.0
	$\leq 19\%$	$> 19\%$	0.8
<u>Withdrawal Loads</u>			
Lag Screws & Wood Screws	any	$\leq 19\%$	1.0
	any	$> 19\%$	0.7
Nails & Spikes ³	$\leq 19\%$	$\leq 19\%$	1.0
	$> 19\%$	$\leq 19\%$	0.25 ³
	$\leq 19\%$	$> 19\%$	0.25 ³
	$> 19\%$	$> 19\%$	1.0
<u>Pull-Through Loads</u>			
Fasteners with Round Heads	any	$\leq 19\%$	1.0
	any	$> 19\%$	0.7

1. For split ring or shear plate connectors, moisture content limitations apply to a depth of 3/4" below the surface of the wood.

2. $C_M = 0.7$ for dowel-type fasteners with diameter, D, less than 1/4".

$C_M = 1.0$ for dowel-type fastener connections with:

- 1) one fastener only, or
- 2) two or more fasteners placed in a single row parallel to grain, or
- 3) fasteners placed in two or more rows parallel to grain with separate splice plates for each row.

3. For Roof Sheathing Ring Shank (RSRS) and Post-Frame Ring Shank (PF) nails, $C_M = 1.0$.

WET SERVICE FACTOR, C_M

service factors

- C_M
- Dowel type connectors

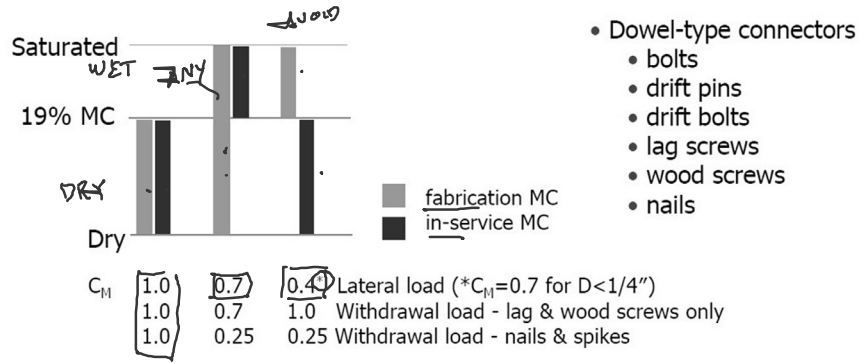

- Dowel-type connectors
 - bolts
 - drift pins
 - drift bolts
 - lag screws
 - wood screws
 - nails

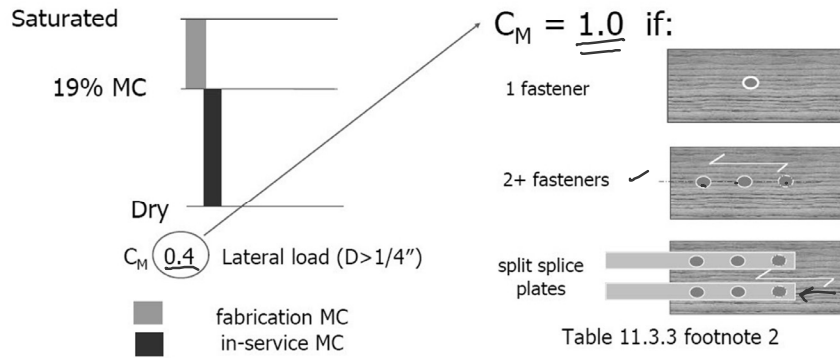

For dowel type fasteners:

service factors

- C_g (chap 11) Group Action Factor
- C_{Δ} (chap 12) Geometry Factor
- C_{eg} (chap 12) End Grain Factor
- C_{di} (chap 12) Diaphragm Factor
- C_{tn} (chap 12) Toe-Nail Factor

11.3.6 Group Action Factors, C_g

11.3.6.1 Reference lateral design values for split ring connectors, shear plate connectors, or dowel-type fasteners with $D \leq 1"$ in a row shall be multiplied by the following group action factor, C_g :

$$C_g = \left[\frac{m(1-m^{2n})}{n[(1+R_{EA}m^n)(1+m)-1+m^{2n}]} \right] \left[\frac{1+R_{EA}}{1-m} \right] \quad (11.3-1)$$

$C_g = 1$ for dowel type fasteners with $D < 1/4"$

Figure 12G Bolted Connection Geometry

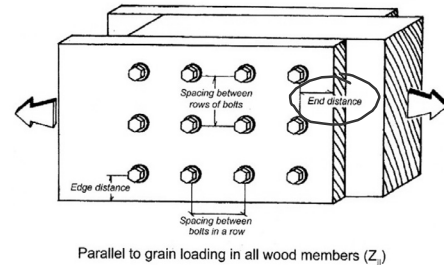

Table 12.5.1A End Distance Requirements

Direction of Loading	End Distances	
	Minimum end distance for $C_A = 0.5$	Minimum end distance for $C_A = 1.0$
Perpendicular to Grain	2D	4D
Parallel to Grain, Compression: (fastener bearing away from member end)	2D	4D
Parallel to Grain, Tension: (fastener bearing toward member end)	3.5D for softwoods 2.5D for hardwoods	7D for $D = 1/2"$ 3 1/2 D

NDS 2018 - Chapter 12

Withdrawal Strength Example

For 16d box nails (NDS Appendix L4)

$D = 0.135''$

$L = 3.5''$

penetration = $3.5 - 1.5 = 2''$

$G = 0.47$ (NDS Table 12.3.3A)

Western Hemlock
green

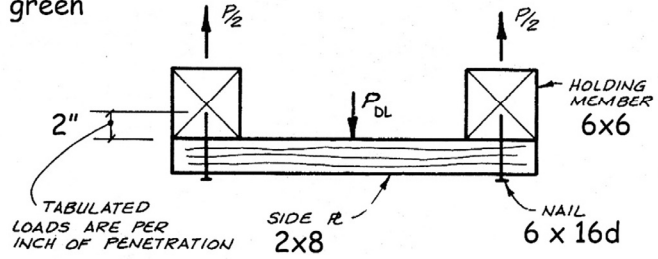

APP

Table L4 Standard Common, Box, and Sinker Steel Wire Nails^{1,2}

Type		Pennyweight										
		6d	7d	8d	10d	12d	16d	20d	30d	40d	50d	60d
Common	L	2	2-1/4	2-1/2	3	3-1/4	3-1/2	4	4-1/2	5	5-1/2	6
	D	0.113	0.113	0.131	0.148	0.148	0.162	0.192	0.207	0.225	0.244	0.263
	H	0.266	0.266	0.281	0.312	0.312	0.344	0.406	0.438	0.469	0.5	0.531
Box	L	2	2-1/4	2-1/2	3	3-1/4	3-1/2	4	4-1/2	5		
	D	0.099	0.099	0.113	0.128	0.128	0.135	0.148	0.148	0.162		
	H	0.266	0.266	0.297	0.312	0.312	0.344	0.375	0.375	0.406		
Sinker	L	1-7/8	2-1/8	2-3/8	2-7/8	3-1/8	3-1/4	3-3/4	4-1/4	4-3/4		5-3/4
	D	0.092	0.099	0.113	0.12	0.135	0.148	0.177	0.192	0.207		0.244
	H	0.234	0.250	0.266	0.281	0.312	0.344	0.375	0.406	0.438		0.5

1. Tolerances are specified in ASTM F1667. Typical shape of common, box, and sinker steel wire nails shown. See ASTM F 1667 for other nail types.
2. It is permitted to assume the length of the tapered tip is 2D.

NDS 2018 - Chapter 12

Withdrawal Strength Example

$G = 0.47$ (NDS Table 12.3.3A)

Withdrawal, $w = 28$ LB/IN (Table 12.2C)

For 16d box nails (NDS Appendix L4)

$D = 0.135''$

$L = 3.5''$

Table 12.2C Smooth Shank (Bright or Galvanized) Carbon Steel Nail and Spike Reference Withdrawal Design Values, $W^{1,3}$

Tabulated withdrawal design values, W , are in pounds per inch of fastener penetration into side grain of wood member (see 12.2.3.1)

Specific Gravity ² , G	Smooth Shank (Bright or Galvanized) Carbon Steel Nail and Spike Diameter, D																	
	0.092"	0.099"	0.113"	0.120"	0.128"	0.131"	0.135"	0.148"	0.162"	0.177"	0.192"	0.207"	0.225"	0.244"	0.263"	0.283"	0.312"	0.375"
0.73	58	62	71	75	80	82	85	93	102	111	121	130	141	153	165	178	196	236
0.71	54	58	66	70	75	77	79	87	95	104	113	121	132	143	154	166	183	220
0.68	48	52	59	63	67	69	71	78	85	93	101	109	118	128	138	149	164	197
0.67	47	50	57	61	65	66	68	75	82	90	97	105	114	124	133	144	158	190
0.58	33	35	40	42	45	46	48	52	57	63	68	73	80	86	93	100	110	133
0.55	28	31	35	37	40	41	42	46	50	55	59	64	70	76	81	88	97	116
0.51	24	25	29	31	33	34	35	38	42	45	49	53	58	63	67	73	80	96
0.50	22	24	28	29	31	32	33	36	40	43	47	50	55	60	64	69	76	91
0.49	21	23	26	28	30	30	31	34	38	41	45	48	52	57	61	66	72	87
0.47	19	21	24	25	27	27	28	31	34	37	40	43	47	51	55	59	65	78
0.46	18	20	22	24	25	26	27	29	32	35	38	41	45	48	52	56	62	74
0.44	16	18	20	21	23	23	24	26	29	31	34	37	40	43	47	50	55	66
0.43	15	17	19	20	21	22	23	25	27	30	32	35	38	41	44	47	52	63
0.42	15	16	18	19	20	21	21	23	26	28	30	33	35	38	41	45	49	59
0.41	14	15	17	18	19	19	20	22	24	26	29	31	33	36	39	42	46	56
0.40	13	14	16	17	18	18	19	21	23	25	27	29	31	34	37	40	44	52
0.39	12	13	15	16	17	17	18	19	21	23	25	27	29	32	34	37	41	49
0.38	11	12	14	15	16	16	17	18	20	22	24	25	28	30	32	35	38	46
0.37	11	11	13	14	15	15	16	17	19	20	22	24	26	28	30	33	36	43
0.36	10	11	12	13	14	14	14	16	17	19	21	22	24	26	28	30	33	40
0.35	9	10	11	12	13	13	14	15	16	18	19	21	23	24	26	28	31	38
0.31	7	7	8	9	9	10	10	11	12	13	14	15	17	18	19	21	23	28

1. Tabulated withdrawal design values, W , for nail or spike connections shall be multiplied by all applicable adjustment factors (see Table 11.3.1).

2. Specific gravity shall be determined in accordance with Table 12.3.3A.

3. Tabulated withdrawal design values for smooth shank nails are permitted to be used for deformed shank nails of equivalent diameter, D .

NDS 2018 - Chapter 12

Withdrawal Strength Example

Withdrawal, $w = 28 \text{ LB/IN}$ (Table 12.2C)

penetration, $p = 2''$

$$W = p \times w = 2'' \times 28 = 56 \text{ LBS/nail}$$

$$W' = W (C_D C_M C_t C_{tn}) = 56(0.9 \cdot 0.25 \cdot 1.0 \cdot 1.0) = 12.6 \text{ LBS/nail}$$

DL ?

Western Hemlock
green

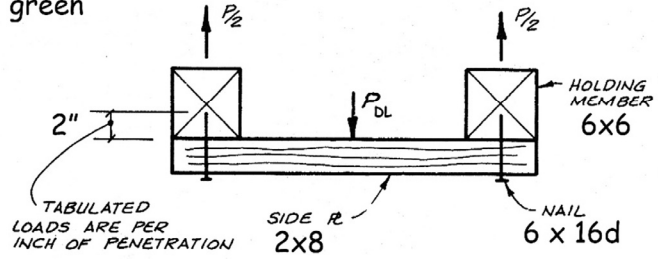

Table 11.3.1 Applicability of Adjustment Factors for Connections

	ASD Only	ASD and LRFD										LRFD Only		
		Load Duration Factor ¹	Wet Service Factor	Temperature Factor	Group Action Factor	Geometry Factor ³	Penetration Depth Factor ³	End Grain Factor ¹	Metal Side Plate Factor ³	Diaphragm Factor ³	Toe-Nail Factor ³	Format Conversion Factor	Resistance Factor	Time Effect Factor
Lateral Loads														
Dowel-type Fasteners (e.g. bolts, lag screws, wood screws, nails, spikes, drift bolts, & drift pins)	$Z' = Z \times$	C_D	C_M	C_t	C_g	C_A	-	C_{eg}	-	C_{di}	C_{di}	3.32	0.65	λ
Split Ring and Shear Plate Connectors	$P = P \times$ $Q = Q \times$	C_D	C_M	C_t	C_g	C_A	C_d	-	C_{st}	-	-	3.32	0.65	λ
Timber Rivets	$P = P \times$ $Q = Q \times$	C_D	C_M	C_t	-	C_A^5	-	-	C_{st}^4	-	-	3.32	0.65	λ
Spike Grids	$Z' = Z \times$	C_D	C_M	C_t	-	C_A	-	-	-	-	-	3.32	0.65	λ
Withdrawal Loads														
Nails, spikes, lag screws, wood screws, & drift pins	$W' = W \times$	C_D	C_M^2	C_t	-	-	-	C_{eg}	-	-	C_{tn}	3.32	0.65	λ
Pull-Through														
Fasteners with Round Heads	$W_H = W_H \times$	C_D	C_M	C_t	-	-	-	-	-	-	-	3.32	0.65	λ

1. The load duration factor, C_D , shall not exceed 1.6 for connections; (see 11.3.2).
 2. The wet service factor, C_M , shall not apply to toe-nails loaded in withdrawal (see 12.5.4.1).
 3. Specific information concerning geometry factors C_A , penetration depth factors C_d and grain factors, C_{eg} , metal side plate factors, C_{di} , diaphragm factors, C_{st} , and toe-nail factors, C_{tn} , is provided in Chapters 12, 13, and 14.
 4. The metal side plate factor, C_{di} , is only applied when rivet capacity (P_r , Q_r) controls (see Chapter 14).
 5. The geometry factor, C_A , is only applied when wood capacity, Q_w , controls (see Chapter 14).

NDS 2018 - Chapter 12

Withdrawal Strength Example

Find the allowable DL capacity
(fabricated green – used dry)

For 16d box nails (NDS Appendix L4)

$$D = 0.135''$$

$$L = 3.5''$$

$$\text{penetration} = 3.5 - 1.5 = 2''$$

$$G = 0.47 \text{ (NDS Table 12.3.3A)}$$

Withdrawal, $w = 28 \text{ LB/IN}$ (Table 12.2C)

penetration, $p = 2''$

$$W = p \times w = 2 \times 28 = 56 \text{ LBS/nail}$$

$$W' = W (C_D C_M C_t C_{tn}) = 56(0.9 \cdot 0.25 \cdot 1.0 \cdot 1.0) = 12.6 \text{ LBS/nail}$$

$$P_{max} = n W' = 12 \times 12.6 = 151 \text{ LBS}$$

Western Hemlock
green

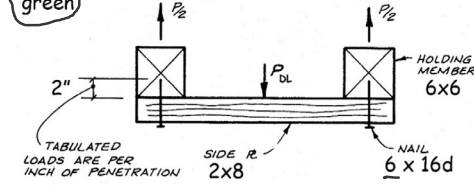

Table 11.3.3 Wet Service Factors, C_M , for Connections

Fastener Type	Moisture Content		C_M
	At Time of Fabrication	In-Service	
Lateral Loads			
Split Ring and Shear Plate Connectors ¹	$\leq 19\%$	$\leq 19\%$	1.0
	$> 19\%$	$\leq 19\%$	0.8
	any	$> 19\%$	0.7
Dowel-type Fasteners (e.g. bolts, lag screws, wood screws, nails, spikes, drift bolts, & drift pins)	$\leq 19\%$	$\leq 19\%$	1.0
	$> 19\%$	$\leq 19\%$	0.4 ²
	any	$> 19\%$	0.7
Timber Rivets	$\leq 19\%$	$\leq 19\%$	1.0
	$\leq 19\%$	$> 19\%$	0.8
Withdrawal Loads			
Lag Screws & Wood Screws	any	$\leq 19\%$	1.0
	any	$> 19\%$	0.7
Nails & Spikes ³	$\leq 19\%$	$\leq 19\%$	1.0
	$> 19\%$	$\leq 19\%$	0.25
	$\leq 19\%$	$> 19\%$	0.25 ²
	$> 19\%$	$> 19\%$	1.0
	any	any	1.0
Pull-Through Loads			
Fasteners with Round Heads	any	$\leq 19\%$	1.0
	any	$> 19\%$	0.7

1. For split ring or shear plate connectors, moisture content limitations apply to a depth of 3/4" below the surface of the wood.
 2. $C_M = 0.7$ for dowel-type fasteners with diameter, D , less than 1/4".
 $C_M = 1.0$ for dowel-type fastener connections with:
 1) one fastener only; or
 2) two or more fasteners placed in a single row parallel to grain; or
 3) fasteners placed in two or more rows parallel to grain with separate splice plates for each row.
 3. For Roof Sheathing Ring Shank (RSRS) and Post-Frame Ring Shank (PF) nails, $C_M = 1.0$.

NDS 2018 Appendix E

Axial Load Connection

three limit states

- E.2 net tension
- E.3 row tear-out
- E.4 group tear-out

LEAST

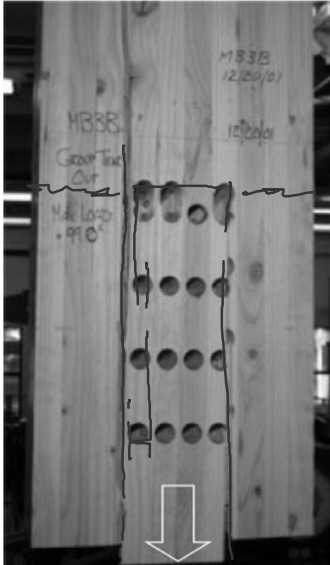

X closely spaced fasteners in group tear-out

Peter von Buelow

Appendix E (Non-mandatory) Local Stresses in Fastener Groups

E.1 General

Where a fastener group is composed of closely spaced fasteners loaded parallel to grain, the capacity of the fastener group may be limited by wood failure at the net section or tear-out around the fasteners caused by local stresses. One method to evaluate member strength for local stresses around fastener groups is outlined in the following procedures.

E.1.1 Reference design values for timber rivet connections in Chapter 14 account for local stress effects and do not require further modification by procedures outlined in this Appendix.

E.1.2 The capacity of connections with closely spaced, large diameter bolts has been shown to be limited by the capacity of the wood surrounding the connection. Connections with groups of smaller diameter fasteners, such as typical nailed connections in wood-frame construction, may not be limited by wood capacity.

E.2 Net Section Tension Capacity

The adjusted tension capacity is calculated in accordance with provisions of 3.1.2 and 3.8.1 as follows:

$$Z_{NT}' = F_t' A_{net} \quad (E.2-1)$$

where:

Z_{NT}' = adjusted tension capacity of net section area

F_t' = adjusted tension design value parallel to grain

A_{net} = net section area per 3.1.2

E.3 Row Tear-Out Capacity

The adjusted tear-out capacity of a row of fasteners can be estimated as follows:

$$Z_{RTi}' = n_i \frac{F_v' A_{s_{critical}}}{2} \quad (E.3-1)$$

where:

Z_{RTi}' = adjusted row tear out capacity of row i

F_v' = adjusted shear design value parallel to grain

$A_{s_{critical}}$ = minimum shear area of any fastener in row i

n_i = number of fasteners in row i

Copyright © American Wood Council. Downloaded/printed pursuant to License Agreement. No reproduction or transfer authorized. AMERICAN WOOD COUNCIL

E.3.1 Assuming one shear line on each side of bolts in a row (observed in tests of bolted connections), Equation E.3-1 becomes:

$$Z_{RTi}' = \frac{F_v' t}{2} [n_i s_{critical}] (2 \text{ shear lines}) \quad (E.3-2)$$

$$= n_i F_v' t s_{critical}$$

where:

$s_{critical}$ = minimum spacing in row i taken as the lesser of the end distance or the spacing between fasteners in row i

t = thickness of member

The total adjusted row tear-out capacity of multiple rows of fasteners can be estimated as:

$$Z_{RT}' = \sum_{i=1}^{n_{row}} Z_{RTi}' \quad (E.3-3)$$

where:

Z_{RT}' = adjusted row tear out capacity of multiple rows

n_{row} = number of rows

E.3.2 In Equation E.3-1, it is assumed that the induced shear stress varies from a maximum value of $f_v = F_v'$ to a minimum value of $f_v = 0$ along each shear line between fasteners in a row and that the change in shear stress/strain is linear along each shear line. The resulting triangular stress distribution on each shear line between fasteners in a row establishes an apparent shear stress equal to half of the adjusted design shear stress, $F_v'/2$, as shown in Equation E.3-1. This assumption is combined with the critical area concept for evaluating stresses in fastener groups and provides good agreement with results from tests of bolted connections.

E.3.3 Use of the minimum shear area of any fastener in a row for calculation of row tear-out capacity is based on the assumption that the smallest shear area between fasteners in a row will limit the capacity of the row of fasteners. Limited verification of this approach is provided from tests of bolted connections.

NDS 2018 Appendix E

Axial Load Connection

three limit states

- E.2 net tension
- E.3 row tear-out
- E.4 group tear-out

Figure E1 Staggered Rows of Bolts

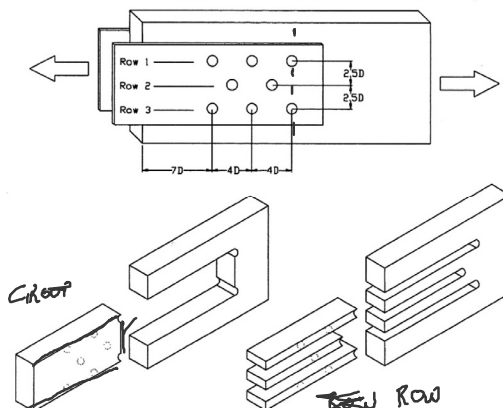

Peter von Buelow

E.4 Group Tear-Out Capacity

The adjusted tear-out capacity of a group of “ n ” rows of fasteners can be estimated as:

$$Z_{GT}' = \frac{Z_{RT-1}'}{2} + \frac{Z_{RT-n}'}{2} + F_t' A_{group-net} \quad (E.4-1)$$

where:

Z_{GT}' = adjusted group tear-out capacity

Z_{RT-1}' = adjusted row tear-out capacity of row 1 of fasteners bounding the critical group area

Z_{RT-n}' = adjusted row tear-out capacity of row n of fasteners bounding the critical group area

$A_{group-net}$ = critical group net section area between row 1 and row n

E.4.1 For groups of fasteners with non-uniform spacing between rows of fasteners various definitions of critical group area should be checked for group tear-out in combination with row tear-out to determine the adjusted capacity of the critical section.

University of Michigan, TCAUP

Slide 22 of 56

Appendix E

• Appendix E NDS Expressions

3 failure modes

- Net tension:

$$Z'_{NT} = F'_t \frac{A_{net}}{A_w - A_{holes}}$$



- Row tear-out:

$$Z'_{RT_i} = n_i F'_v t s'_{min}$$

$$Z'_{RT} = \sum_{i=1}^{n_{row}} Z'_{RT_i}$$

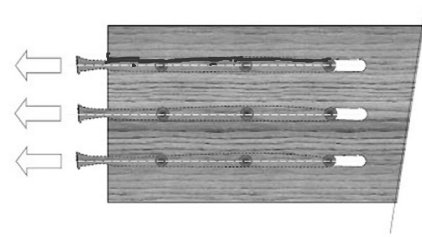

- Group tear-out

$$Z'_{GT} = \frac{Z'_{RT-top}}{2} + \frac{Z'_{RT-bottom}}{2} + F'_t A_{group-net}$$

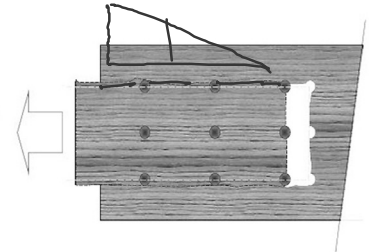

•Note: spacing between outer rows of fasteners paralleling the member on a single splice plate $\leq 5''$

Chapter 12

Connection Yield Modes

Yield Limit Equations for Dowel Fasteners
Table 12.3.1A

Single Shear Connections

$$Z = \frac{D \ell_m F_{em}}{R_d} \quad (12.3-1)$$

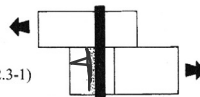

Mode I_m

$$Z = \frac{D \ell_s F_{es}}{R_d} \quad (12.3-2)$$

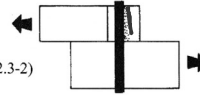

Mode I_s

$$Z = \frac{k_1 D \ell_s F_{es}}{R_d} \quad (12.3-3)$$

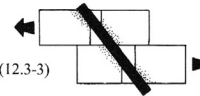

Mode II

$$Z = \frac{k_2 D \ell_m F_{em}}{(1+2R_d) R_d} \quad (12.3-4)$$



Mode III_m

$$Z = \frac{k_3 D \ell_s F_{em}}{(2+R_d) R_d} \quad (12.3-5)$$



Mode III_s

$$Z = \frac{D^2}{R_d} \sqrt{\frac{2F_{em} F_{yo}}{3(1+R_d)}} \quad (12.3-6)$$

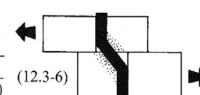

Mode IV

Double Shear Connections

$$Z = \frac{D \ell_m F_{em}}{R_d} \quad (12.3-7)$$

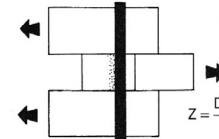

Mode I_m

$$Z = \frac{2D \ell_s F_{es}}{R_d} \quad (12.3-8)$$

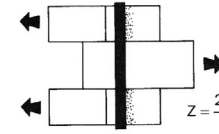

Mode I_s

(not applicable)

(not applicable)

$$Z = \frac{2k_3 D \ell_s F_{em}}{(2+R_d) R_d} \quad (12.3-9)$$

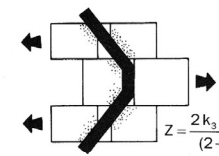

Mode III_s

$$Z = \frac{2D^2}{R_d} \sqrt{\frac{2F_{em} F_{yo}}{3(1+R_d)}} \quad (12.3-10)$$

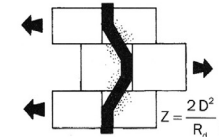

Mode IV

lap splice connection example – 1” bolts w/ $1-1/16$ ” holes

BOLTED SPLICE – LOCAL STRESSES

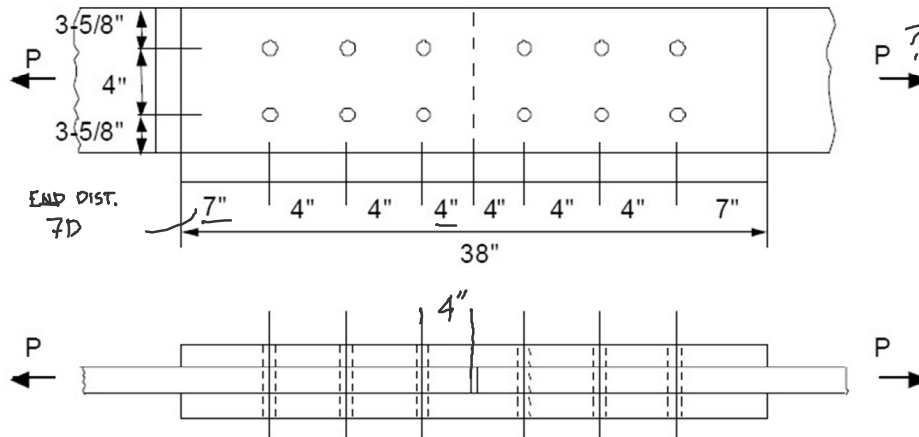

NDS Appendix E

tension connection – 2x12’s So.Pine No.2 $C_D = 1.25$

net tension check

EXAMPLE: BOLTED SPLICE – LOCAL STRESSES

• Assume 1” diameter x 5” long bolts

• 2x12 No. 2 Southern Pine main and side members

Net Section Tension Check

$$Z_{NT}' = F_t' A_{net}$$

$$F_t' = 450(1.25) = 562.5 \text{ psi}$$

$$A_{net} = 13.7 \text{ in}^2 = 16.88 - [2(1.0625 \times 1.5)]$$

$$Z_{NT}' = 7,706 \text{ lbs}$$

E.2 Net Section Tension Capacity

The adjusted tension capacity is calculated in accordance with provisions of 3.1.2 and 3.8.1 as follows:

$$Z_{NT}' = F_t' A_{net} \quad (\text{E.2-1})$$

where:

Z_{NT}' = adjusted tension capacity of net section area

F_t' = adjusted tension design value parallel to grain

A_{net} = net section area per 3.1.2

Note: hole size for net area includes $1/16$ ” oversizing per NDS 12.1.3.2

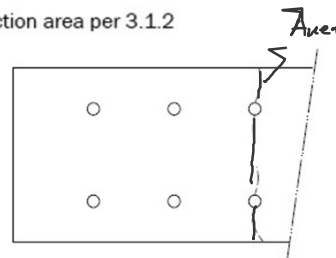

NDS Appendix E

tension connection – 2x12's So.Pine No.2 $C_D = 1.25$

row tear-out check

EXAMPLE: BOLTED SPLICE – LOCAL STRESSES

Row Tear-Out Check

$$Z_{RTi}' = n_i F_v' t s_{critical}$$

$$n_i = 3$$

$$F_v' = 175(1.25) = 219 \text{ psi}$$

$$t = 1.5''$$

$$s_{critical} = 4''$$

$$Z_{RT1}' = 3,938 \text{ lbs for one row}$$

$$Z_{RT2}' = 7,875 \text{ lbs for two rows}$$

Note: $s_{critical}$ is the minimum of the end distance and the in-row bolt spacing = 4''

E.3 Row Tear-Out Capacity

The adjusted tear-out capacity of a row of fasteners can be estimated as follows:

$$Z_{RTi}' = n_i \frac{F_v' A_{critical}}{2} \quad (E.3-1)$$

$$Z_{RTi}' = \frac{F_v' t}{2} [n_i s_{critical}] \quad (E.3-2)$$

~~(2 shear lines)~~

$$= n_i F_v' t s_{critical}$$

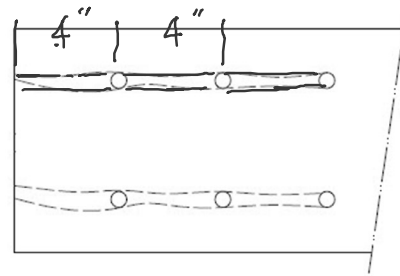

NDS Appendix E

tension connection – 2x12's So.Pine No.2 $C_D = 1.25$

group tear-out check $A_{group-net} = (4 - 1 \frac{1}{16}) 1.5 = 4.406 \text{ in}^2$

EXAMPLE: BOLTED SPLICE – LOCAL STRESSES

Group Tear-Out Check

$$Z_{GT}' = Z_{RT1}'/2 + Z_{RT2}'/2 + F_t' A_{group-net}$$

$$Z_{RT1}' = Z_{RT2}' = 3,938 \text{ lbs}$$

$$F_t' = 450(1.25) = 562.5 \text{ psi}$$

$$A_{group-net} = 4.41 \text{ in}^2$$

$$Z_{GT}' = 6,418 \text{ lbs}$$

Note: hole size for net area includes 1/16'' oversizing per NDS 12.1.3.2

E.4 Group Tear-Out Capacity

The adjusted tear-out capacity of a group of "n" rows of fasteners can be estimated as:

$$Z_{GT}' = \frac{Z_{RT-1}'}{2} + \frac{Z_{RT-n}'}{2} + F_t' A_{group-net} \quad (E.4-1)$$

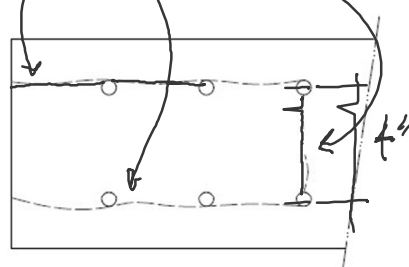

Chapter 12

Connection Yield Modes

Yield Limit Equations
for Dowel Fasteners
Table 12.3.1A

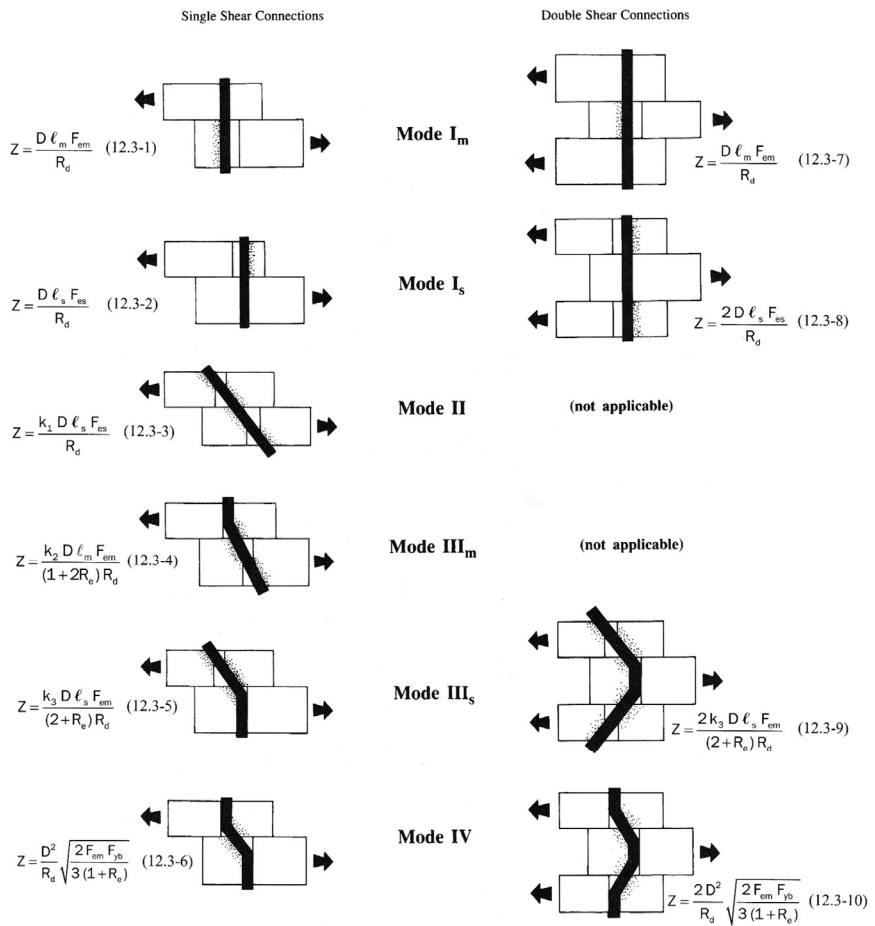

NDS Appendix E

tension connection – 2x12's So.Pine No.2 C_D = 1.25
fastener yield limit equations

D = 1 IN *BOLT*
F_{yb} = 45000 PSI
R_d (Table 12.3.1B) 4
R_e = 1
R_t = 1
ℓ_m = 1.5 IN
ℓ_s = 1.5 IN
F_{em} = 6150 PSI
F_{es} = 6150 PSI
k₃ = 2.241

Z = 2306 LBS (least)
adjustment factors:
C_D = 1.25 *LL*
C_g = 0.97
C_Δ = 0.571 *4"*
C_M = C_t = 1.0

Table 12.3.1A Yield Limit Equations

Yield Mode	Single Shear	Double Shear
I _m	$Z = \frac{D \ell_m F_{em}}{R_d}$ (12.3-1)	$Z = \frac{D \ell_m F_{em}}{R_d} = 2306 \text{ LBS}$ (12.3-7)
I _s	$Z = \frac{D \ell_s F_{es}}{R_d}$ (12.3-2)	$Z = \frac{2D \ell_s F_{es}}{R_d} = 4613 \text{ LBS}$ (12.3-8)
II	$Z = \frac{k_1 D \ell_s F_{es}}{R_d}$ (12.3-3)	
III _m	$Z = \frac{k_2 D \ell_m F_{em}}{(1+2R_e) R_d}$ (12.3-4)	
III _s	$Z = \frac{k_3 D \ell_s F_{em}}{(2+R_e) R_d}$ (12.3-5)	$Z = \frac{2k_3 D \ell_s F_{em}}{(2+R_e) R_d} = 4307 \text{ LBS}$ (12.3-9)
IV	$Z = \frac{D^2}{R_d} \sqrt{\frac{2F_{em} F_{yb}}{3(1+R_e)}}$ (12.3-6)	$Z = \frac{2D^2}{R_d} \sqrt{\frac{2F_{em} F_{yb}}{3(1+R_e)}} = 6003 \text{ LBS}$ (12.3-10)

Notes:

$$k_1 = \frac{\sqrt{R_e + 2R_e^2(1+R_t+R_t^2) + R_t^2 R_e^3} - R_e(1+R_t)}{(1+R_e)}$$

$$k_2 = -1 + \sqrt{2(1+R_e) + \frac{2F_{yb}(1+2R_e)D^2}{3F_{em}\ell_m^2}}$$

$$k_3 = -1 + \sqrt{\frac{2(1+R_e) + 2F_{yb}(2+R_e)D^2}{R_e + 3F_{em}\ell_s^2}}$$

D = diameter, in. (see 12.3.7)
F_{yb} = dowel bending yield strength, psi
R_d = reduction term (see Table 12.3.1B)
R_e = F_{em}/F_{es}
R_t = ℓ_m/ℓ_s
ℓ_m = main member dowel bearing length, in.
ℓ_s = side member dowel bearing length, in.
F_{em} = main member dowel bearing strength, psi (see Table 12.3.3)
F_{es} = side member dowel bearing strength, psi (see Table 12.3.3)

Z' = 1598 lb/ bolt = **9589 LBS total**

NDS Chapter 12

Table 12F for :

$t_m = 1.5"$

$t_s = 1.5"$

$D = 1"$

$G = 0.55$

from eq. 12.3-7 :

$$Z_{||} = 2306 \text{ LBS / bolt}$$

from table 12F

$$Z_{||} = 2310 \text{ LBS / bolt}$$

then

adjustment factors:

$$C_D = 1.25$$

$$C_g = 0.97$$

$$C_{\Delta} = 0.571$$

$$C_M = C_t = 1.0$$

$$Z (\text{adj. factors}) = Z' \times C_{\text{Bolts}}$$

$$Z' = 1599 \text{ lb/ bolt} = \mathbf{9596 \text{ LBS total}}$$

Peter von Buelow

BOLTS

Table 12F BOLTS: Reference Lateral Design Values, Z, for Double Shear

(three member) Connections^{1,2}

for sawn lumber or SCL with all members of identical specific gravity



Main Member Thickness t_m in.	Side Member Thickness t_s in.	Bolt Diameter in.	G=0.67 Red Oak			G=0.55 Mixed Maple Southern Pine			G=0.50 Douglas Fir-Larch			G=0.49 Douglas Fir-Larch(N)			G=0.46 Douglas Fir(S) Hem-Fir(N)		
			$Z_{ }$ lbs.	Z_{\perp} lbs.	Z_{\perp} lbs.	$Z_{ }$ lbs.	Z_{\perp} lbs.	Z_{\perp} lbs.	$Z_{ }$ lbs.	Z_{\perp} lbs.	Z_{\perp} lbs.	$Z_{ }$ lbs.	Z_{\perp} lbs.	Z_{\perp} lbs.	$Z_{ }$ lbs.	Z_{\perp} lbs.	Z_{\perp} lbs.
1-1/2	1-1/2	1/2	1410	960	730	1150	800	550	1050	730	470	1030	720	460	970	680	420
		5/8	1760	1310	810	1440	1130	610	1310	1040	530	1290	1030	520	1210	940	470
		3/4	2110	1690	890	1730	1330	660	1580	1170	590	1550	1130	560	1450	1040	520
		7/8	2460	1920	950	2020	1440	720	1840	1280	630	1800	1210	600	1680	1130	550
1-3/4	1-3/4	1/2	1640	1030	850	1330	850	640	1230	770	550	1200	750	530	1130	710	490
		5/8	2050	1370	940	1680	1160	710	1530	1070	610	1500	1060	600	1410	1000	550
		3/4	2460	1810	1040	2020	1550	770	1840	1370	680	1800	1310	660	1690	1210	600
		7/8	2870	2240	1120	2350	1680	840	2140	1470	740	2110	1410	700	1970	1290	640
2-1/2	1-1/2	1/2	1530	960	1120	1320	800	910	1230	730	790	1210	720	760	1160	680	700
		5/8	2150	1310	1340	1870	1130	1020	1760	1040	880	1740	1030	860	1660	940	780
		3/4	2890	1770	1480	2550	1330	1110	2400	1170	980	2380	1130	940	2280	1040	860
		7/8	3780	1920	1600	3360	1440	1200	3060	1260	1050	3010	1210	1010	2820	1100	920
3-1/2	1-1/2	1	4690	2040	1700	3840	1530	1280	3500	1350	1130	3440	1290	1080	3220	1200	1000
		5/8	2150	1310	1510	1320	800	940	1230	730	860	1210	720	850	1160	680	810
		3/4	2890	1770	1980	2550	1330	1550	2400	1170	1370	2380	1130	1170	2280	940	1090
		7/8	3780	1920	2240	3360	1440	1680	3180	1260	1470	3150	1210	1410	3030	1100	1290
3-1/2	1-3/4	1/2	1660	1180	1180	1500	1040	1040	1430	970	970	1420	960	960	1370	920	920
		5/8	2310	1370	1630	1990	1160	1380	1860	1070	1230	1840	1060	1200	1760	1000	1090
		3/4	3730	2380	2070	3380	1910	1550	3220	1750	1370	3190	1700	1310	3090	1610	1210
		7/8	5080	2820	2240	4600	2330	1690	4290	2130	1470	4210	2070	1410	3940	1980	1290
5-1/4	1-1/2	1	4820	2040	2380	4310	1530	1790	4090	1350	1580	4050	1290	1510	3860	1200	1400
		5/8	2150	1310	1510	1870	1130	1290	1760	1040	1190	1740	1030	1170	1660	940	1110
		3/4	2890	1770	1980	2550	1330	1690	2400	1170	1580	2380	1130	1550	2280	1040	1480
		7/8	3780	1920	2520	3360	1440	2170	3180	1260	2030	3150	1210	1990	3030	1100	1900
5-1/2	1-1/2	1	4820	2040	3120	4310	1530	2700	4090	1350	2480	4050	1290	2370	3860	1200	2200
		5/8	2590	1770	1770	2340	1560	1560	2240	1410	1460	2220	1390	1450	2150	1290	1390
		3/4	3730	2380	2480	3380	1910	2180	3220	1750	2050	3190	1700	1970	3090	1610	1810
		7/8	5080	2820	3290	4600	2330	2530	4390	2130	2210	4350	2070	2110	4130	1980	1930
7-1/2	1-1/2	1	6630	3340	3570	5740	2780	2680	5330	2580	2360	5250	2520	2260	4990	2410	2100
		5/8	2150	1310	1510	1870	1130	1290	1760	1040	1190	1740	1030	1170	1660	940	1110
		3/4	2890	1770	1980	2550	1330	1690	2400	1170	1580	2380	1130	1550	2280	1040	1480
		7/8	3780	1920	2520	3360	1440	2170	3180	1260	2030	3150	1210	1990	3030	1100	1900
7-1/2	3-1/2	1	4820	2040	3120	4310	1530	2700	4090	1350	2480	4050	1290	2370	3860	1200	2200
		5/8	2590	1770	1770	2340	1560	1560	2240	1410	1460	2220	1390	1450	2150	1290	1390
		3/4	3730	2380	2480	3380	1910	2180	3220	1750	2050	3190	1700	1970	3090	1610	1810
		7/8	5080	2820	3290	4600	2330	2530	4390	2130	2210	4350	2070	2210	4130	1980	2020

1. Tabulated lateral design values, Z, for bolted connections shall be multiplied by all applicable adjustment factors: (see Table 11.3.1).
2. Tabulated lateral design values, Z, are for "full-body diameter" bolts: (see Appendix Table L1) with bolt bending yield strength, F_u , of 45,000 psi.

NDS Appendix E 3-member connection – 2x12's So.Pine No.2 $C_D = 1.25$

results

EXAMPLE: BOLTED SPLICE – LOCAL STRESSES

Final Bolt Capacity

$$Z' = 9,602 \text{ lbs Bolts}$$

$$Z_{NT}' = 7,706 \text{ lbs}$$

$$Z_{RT}' = 7,875 \text{ lbs}$$

$$Z_{GT}' = 6,418 \text{ lbs}$$

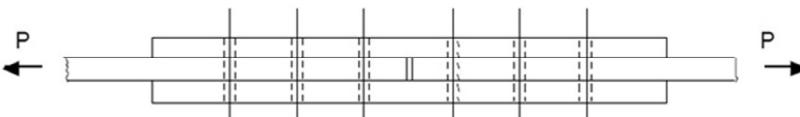
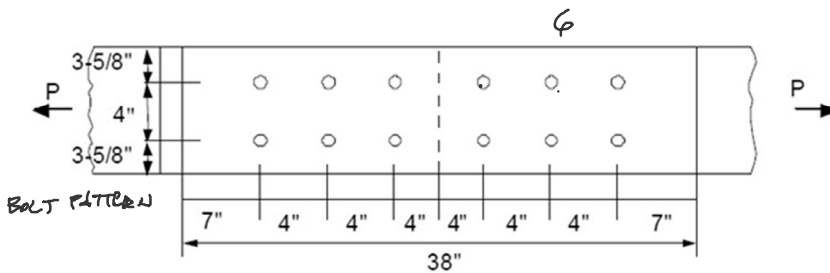
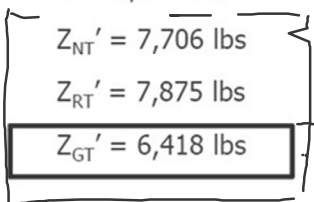

Connection Details

Avoid tension perpendicular to grain

Situations

- notches
- large diameter fasteners
- hanging loads

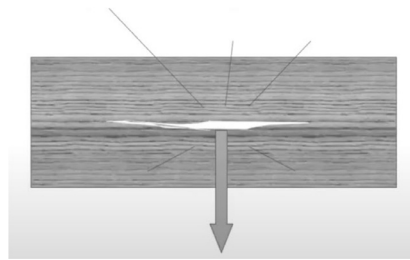

NOTCHING

Problem

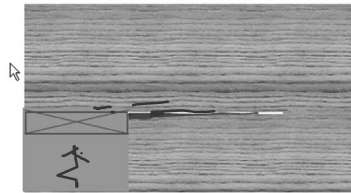

Solution

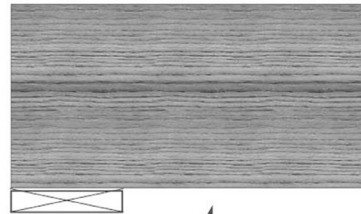

Connection Details

BEAM TO CONCRETE

Notches

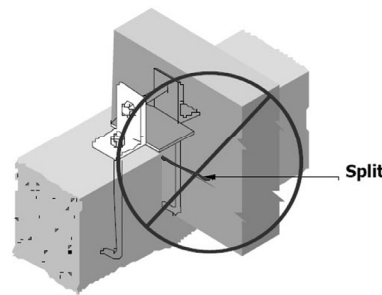

Notched Beam Bearing

- may cause splitting
- not recommended

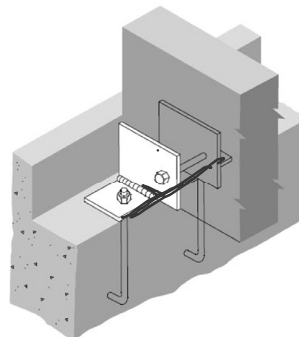

Bearing Wall

- alternate to beam notch



Connection Details

Hangers

HANGER TO BEAM

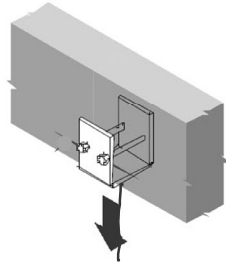

Load suspended from lower half of beam

- Tension perpendicular to grain
- May cause splits

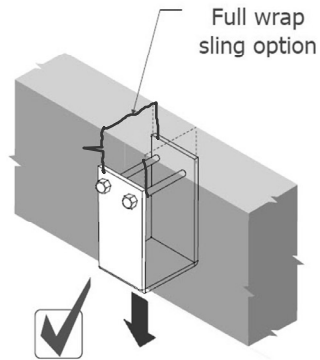
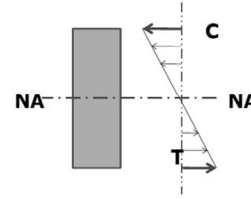

Load supported in upper half of beam

- Above the neutral axis

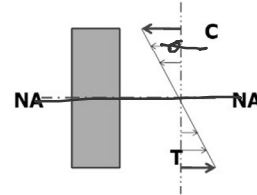

Connection Details

exposure to moisture

- end grain wicks water
- natural decay resistant species – e.g. cedar
- treated lumber

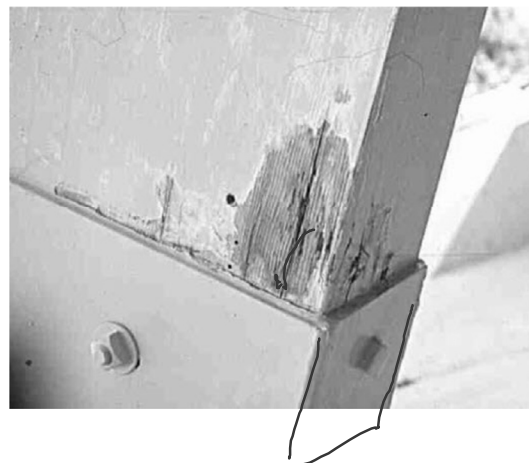
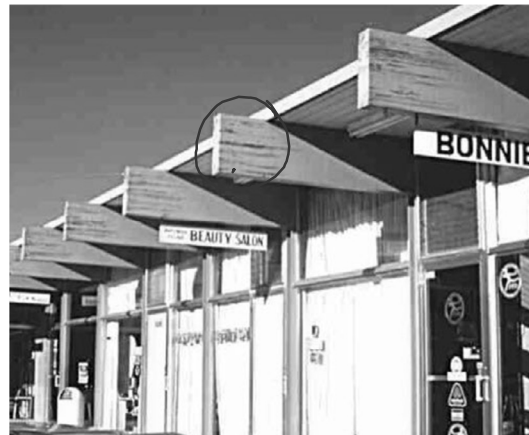
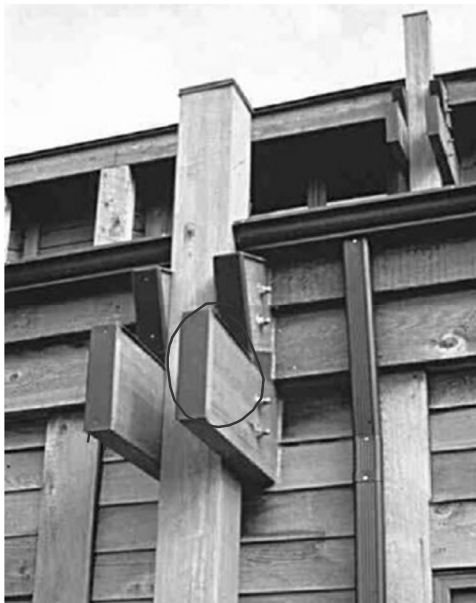

Connection Details

BEAM TO COLUMN

splitting due to shrinkage

Full-depth side plates

- may cause splitting
- wood shrinkage

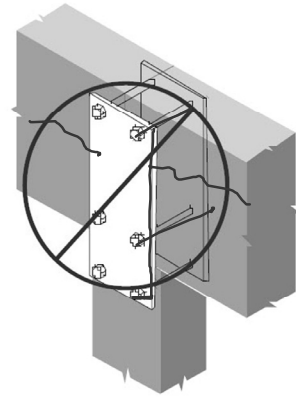

Smaller side plates

- transmit force
- allow wood movement

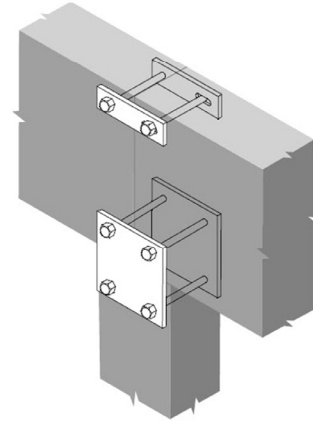

Connection Details

water damage
shrinkage splitting

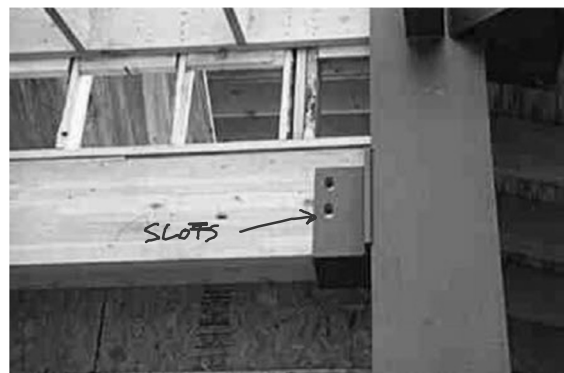
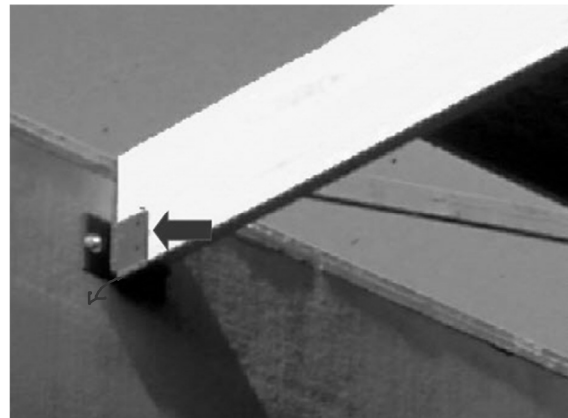

Solutions

- connectors at base
- slotted connectors

Connection Details

Water damage

- avoid contact with concrete or masonry
- provide $\frac{1}{2}$ " air gap
- provide weep holes



Connection Details

Water damage

- avoid contact with concrete or masonry
- provide $\frac{1}{2}$ " air gap
- provide weep holes

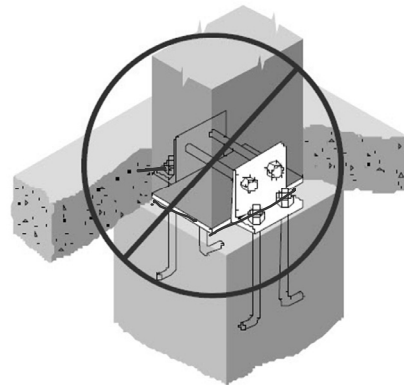

BEAM TO CONCRETE

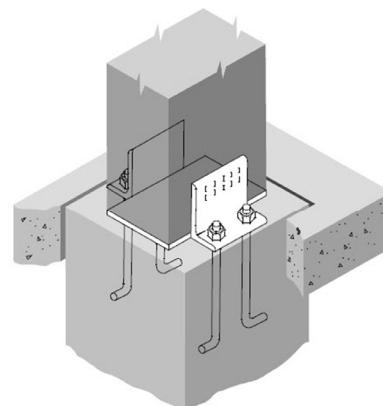
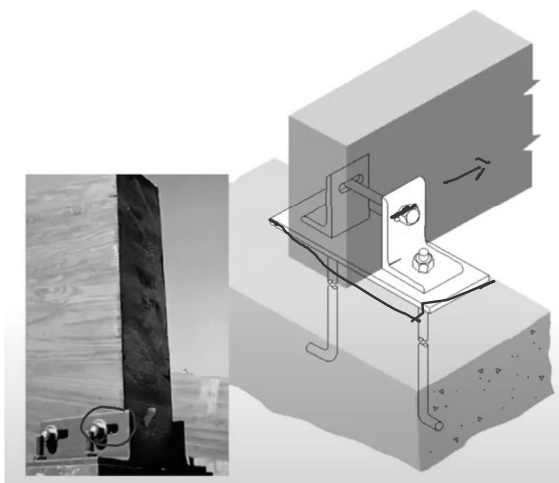

Connection Details

Seismic forces

- diaphragm connections to walls

- Wood Diaphragms

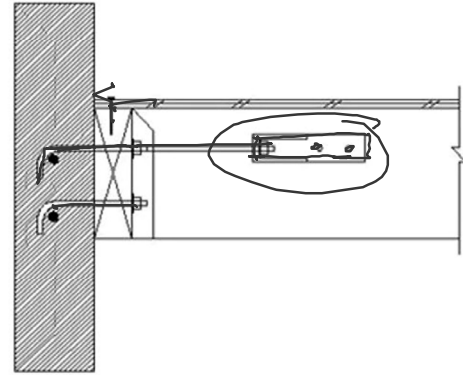

Peter von Buelow

University of Michigan, TCAUP

Slide 43 of 56

Connection Details

Seismic forces

- shear walls

SHEAR WALL - PARTS

Five parts of a shear wall

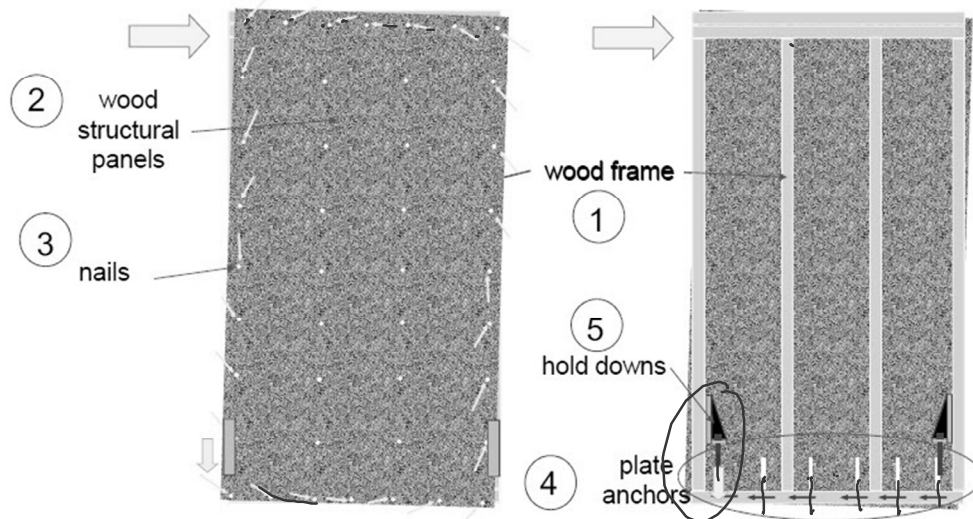

Peter von Buelow

University of Michigan, TCAUP

Slide 44 of 56

Connection Details

Seismic forces

- shear walls

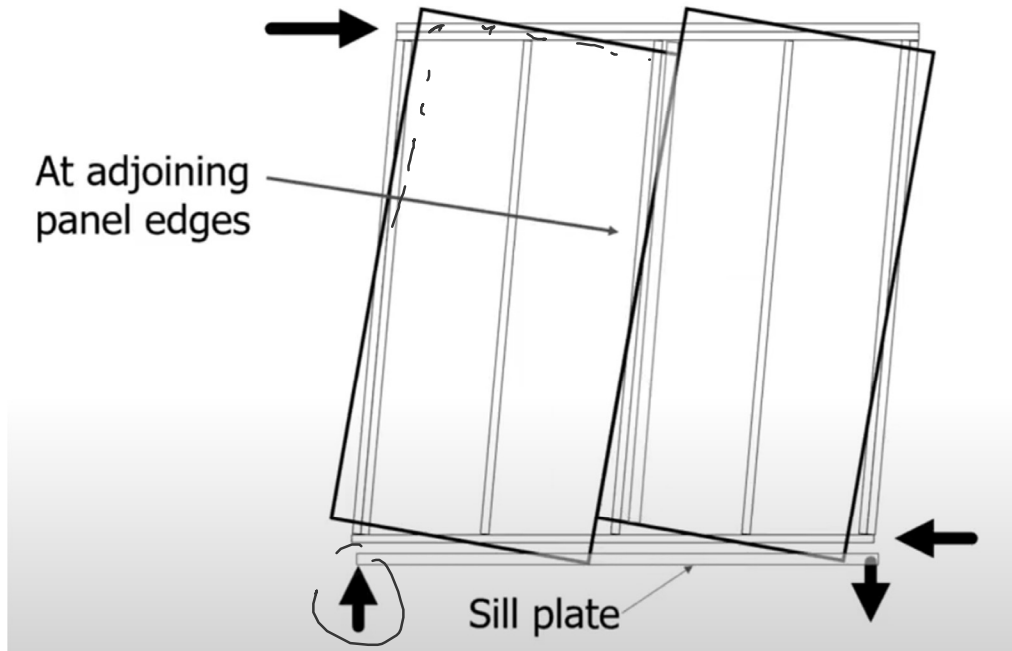

Connection Details

STAGGERED NAILING

Seismic forces

- shear walls

3" OR 2x2"

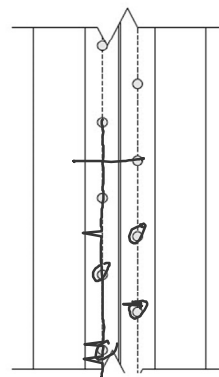

Nailing not staggered

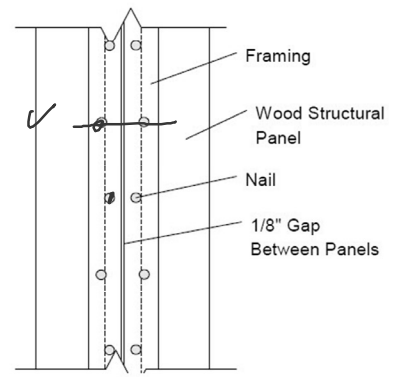

Nailing staggered

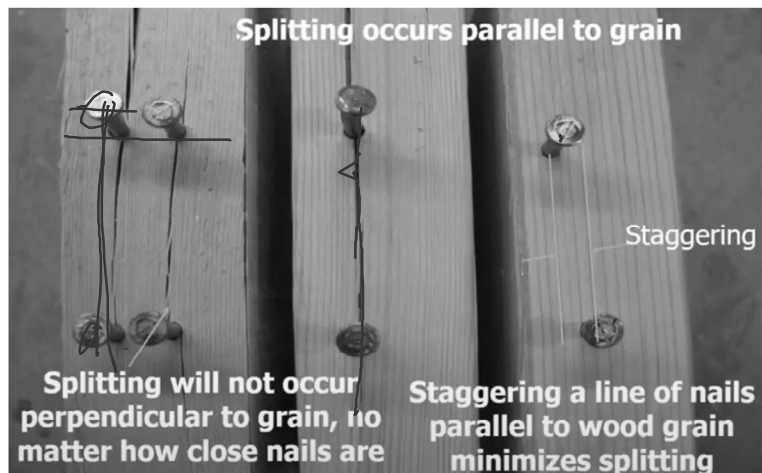

Connection Details

Seismic forces

- shear walls



3X AT ADJOINING PANEL EDGE



Section 4.3.7.1(4). 3x framing also required at adjoining panel edges where:

- Nail spacing of 2 in. o.c.
- 10d common nails having penetration of more than 1-1/2 in. at 3 in. o.c. or less
- Nominal unit shear capacity on either side exceeds 700 plf in SDC D, E, or F

Exception: (2) 2x framing permitted in lieu of (1) 3x where fastened in accordance with the NDS to transfer the induced shear between members.

APA

Connection Details

Seismic forces

- shear walls

CH. 4 - SHEAR WALLS SHEATHED ON 2 SIDES

Adjoining Panel Edge Details

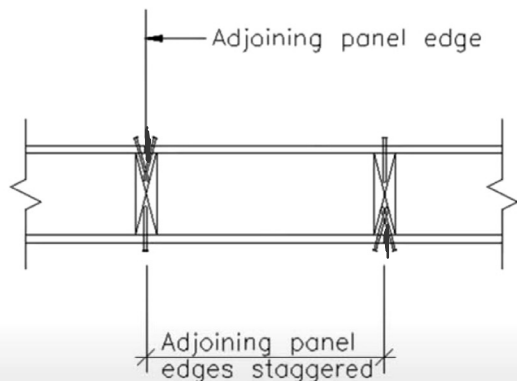

a. Adjoining panel edges staggered

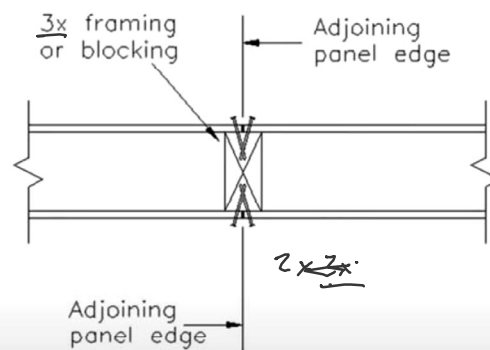

b. Adjoining panel edges not staggered

What's Better 2X6 Walls or 2X4 Walls?

Residential Details IRC & IBC

Floor

Floor

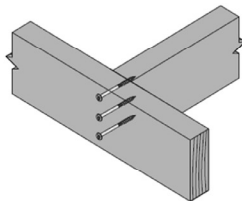

Joist to Rim Board
(End Screw)

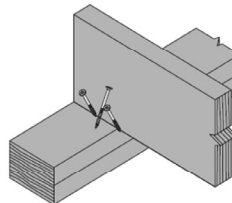

Joist to Sill or Girder
(Toe Screw)

Connection Application	Fastener Quantities			
	IRC		IBC	
	Nails per Table R602.3 (1)	Equivalent SDWS Framing Screws	Nails per Table 2304.10.1	Equivalent SDWS Framing Screws
Joist to band joist (end screw)	(3) 16d common end nail	(3) SDWS16300	(3) 16d common	(3) SDWS16300
Joist to sill or girder (toe screw)	(3) 8d box	(3) SDWS16212	(3) 8d common	(3) SDWS16212

Residential Details

IRC & IBC

Beams

Beam

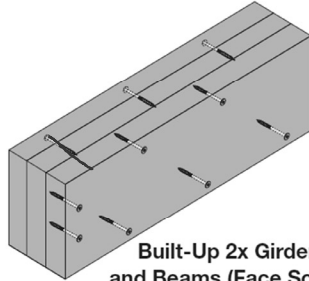

Built-Up 2x Girders and Beams (Face Screw)

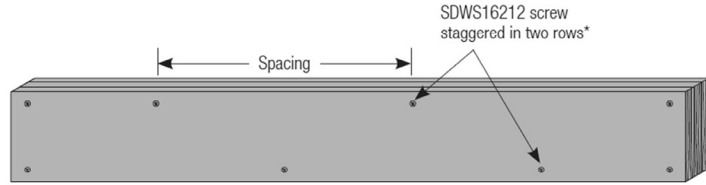

Beam Assembly Detail*

Connection Application	Fastener Quantities and Spacing			
	IRC		IBC	
	Nails per Table R602.3 (1)	Equivalent SDWS Framing Screws	Nails per Table 2304.10.1	Equivalent SDWS Framing Screws
Built-up 2x girders and beams (face screw)	10d box 32" o.c. (24" o.c. per 2015)	SDWS16212 32" o.c.	10d box 24" o.c.	SDWS16212 24" o.c.

*Fastening pattern shown applies to each ply of the built-up 2x beam.

Residential Details

IRC & IBC

Walls

Walls

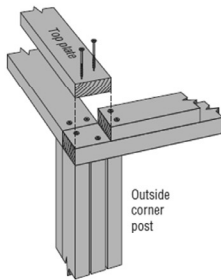

Double Top Plate at Corners

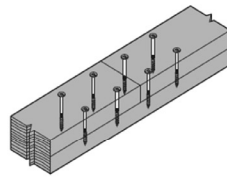

Double Top Plate Laps (Face Screw)

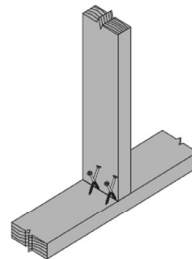

Stud to Sole Plate (Toe Screw)

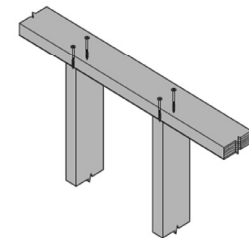

Top or Sole Plate to Stud (End Screw)

Connection Application	Fastener Quantities			
	IRC		IBC	
	Nails per Table R602.3 (1)	Equivalent SDWS Framing Screws	Nails per Table 2304.10.1	Equivalent SDWS Framing Screws
Top or sole plate to stud (end screw)	(2) 16d box	(2) SDWS16212	(2) 16d common	(2) SDWS16300
Stud to sole plate (toe screw)	(2) 16d box	(2) SDWS16212	(4) 8d common	(4) SDWS16212
Double top plate laps (face screw)	(8) 16d box	(8) SDWS16212	(8) 16d common	(8) SDWS16300
Double top plate at corners and intersections (face screw)	(2) 10d box	(2) SDWS16212	(2) 16d common	(2) SDWS16212
Double studs (face screw)	10d box 24" o.c.	SDWS16212 24" o.c.	16d box 24" o.c.	SDWS16300 24" o.c.

Residential Details

IRC & IBC

Ceiling

Ceiling

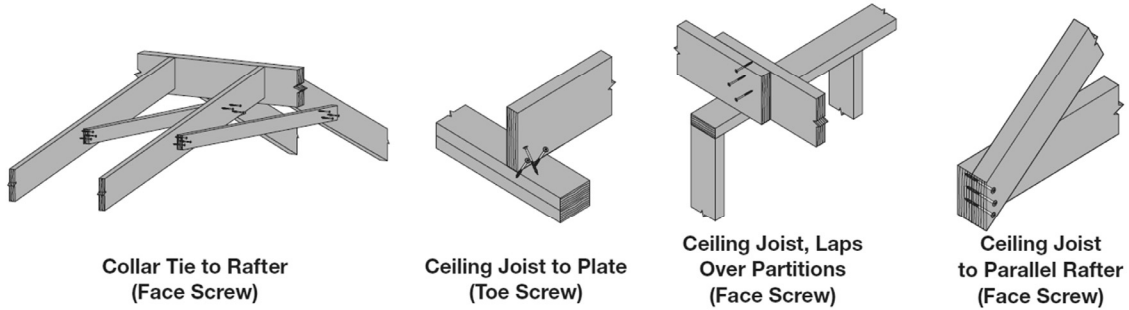

Connection Application	Fastener Quantities			
	IRC		IBC	
	Nails per Table R602.3 (1) and R802.5.2	Equivalent SDWS Framing Screws	Nails per Table 2304.10.1	Equivalent SDWS Framing Screws
Ceiling joist to plate (toe screw)	(3) 8d box	(3) SDWS16212	(3) 8d common	(3) SDWS16212
Ceiling joists, lap over partitions (face screw)	(3 min*) 10d box	(3 min*) SDWS16212	(3 min*) 16d common	(3 min*) SDWS16300
Collar tie to rafter (face screw)	(3) 10d box	(3) SDWS16212	(3) 10d common	(3) SDWS16300
Ceiling joist to parallel rafters (face screw)	(3) 16d common*	(3) SDWS16300*	(3 min*) 16d common	(3 min*) SDWS16300

*Quantities vary based on project conditions. The SDWS16300 is a 1-for-1 replacement for 16d common nails.

Residential Details

IRC & IBC

Roof

Roof

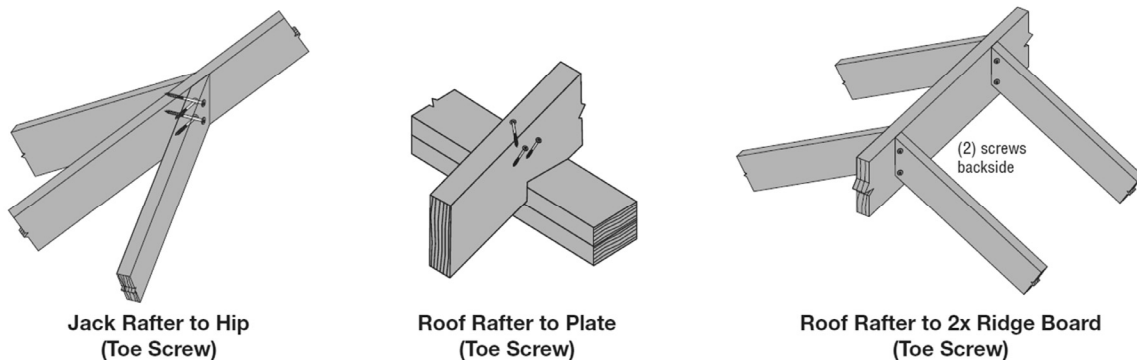

Connection Application	Fastener Quantities			
	IRC		IBC	
	Nails per Table R602.3 (1)	Equivalent SDWS Framing Screws	Nails per Table 2304.10.1	Equivalent SDWS Framing Screws
Roof rafter to plate (toe screw)	(3) 10d common	(3) SDWS16212	(3) 8d common	(3) SDWS16212
Roof rafter to 2x ridge board (toe screw)	(4) 16d box	(4) SDWS16212	(2) 16d common	(2) SDWS16300
Jack rafter to hip (toe screw)	(4) 16d box	(4) SDWS16212	(3) 10d common	(3) SDWS16300

Simpson Strong-Tie Connectors



Framing Details

